

Detects failures in SSRs used for heater temperature control and simultaneously outputs alarm signals. This product supports the safe design of heater control systems, and contributes to maintenance improvements by the user.

- Main detection items:
SSR short-circuits and SSR open-circuits
- Alarm output possible to NPN/PNP-input devices.
- The failure-detection function is built-in and power is supplied from the main circuit power supply making wiring simple.
- Slim design (width: 22.5 mm) incorporating radiator.
- In addition to screw mounting, DIN track mounting is also possible.
- Conforms to international standards (IEC, UL, and CSA).



Ordering Information

Insulation method	Zero-cross function	Indicators	Applicable output load	Model number
Phototriac coupler	Yes	Yes (See page 6)	20 A, 100 to 240 VAC (resistive load: AC, Class1)	G3PC-220B-VD

■ Accessories (Order Separately)

Name	Dimensions	Model number
Mounting Track	50 cm (l) × 7.3 mm (t)	PFP-50N
	1 m (l) × 7.3 mm (t)	PFP-100N
	1 m (l) × 16 mm (t)	PFP-100N2

Specifications

■ Ratings (At an Ambient Temperature of 25°C)

Detection Power Supply

Rated power supply voltage	100 to 240 VAC (50/60 Hz)
Operating voltage range	75 to 264 VAC (50/60 Hz)
Current consumption	15 mA max. (at 200 VAC)

Operating Circuit

Input method	Voltage input
Rated input voltage	12 to 24 VDC
Operating input voltage range	9.6 to 30 VDC
Must-operate voltage	9.6 VDC max.
Reset voltage	1 VDC min.
Input current	7 mA DC max. (at rated input voltage)

Main Circuit

Rated load voltage	100 to 240 VAC (50/60 Hz)
Operating voltage range	75 to 264 VDC (50/60 Hz)
Rated carry current	20 A (Ta = 40)
Minimum load current	0.1 A
Inrush current resistance (peak value)	220 A (60 Hz, 1 cycle)
Permissible (I ² t)	260 A ² S
Applicable load (with Class-1 AC resistive load)	4 kW (at 200 VAC)

Alarm Output

Output OFF collector voltage	30 VDC max.
Maximum carry current	0.1 A
Output form	Independent NPN open collector

■ Characteristics

Operate time		1/2 of load power source cycle + 1 ms max.																		
Release time		1/2 of load power source cycle + 1 ms max.																		
Main circuit	Output ON voltage drop	1.6 V rms max.																		
	OFF leakage current	10 mA max. (at 200 VAC)																		
Alarm output	Output ON voltage drop	1.5 V max.																		
	OFF leakage current	0.1 mA max.																		
Insulation resistance		100 MΩ min. (at 500 VDC)																		
Dielectric strength		2,500 VAC, 50/60 Hz for 1 min																		
Vibration resistance		10 to 55 to 10 Hz, 0.35-mm single amplitude																		
Shock resistance		294 m/s ²																		
Ambient temperature		Operating: -20 to 60°C (with no icing or condensation) Storage: -30 to 70°C (with no icing or condensation)																		
Ambient operating humidity		45% to 85%																		
Weight		Approx. 300 g																		
Approved standards		UL508, CSA22.2 No. 14, EN60947-4-3 (IEC947-4-3) approved by VDE																		
EMC		<table border="0"> <tr> <td>Emission</td> <td>ESD</td> <td>EN55011 Group 1 Class B IEC947-4-3, EN61000-4-2 4 kV contact discharge 8 kV air discharge</td> </tr> <tr> <td>Immunity</td> <td>Electromagnetic</td> <td>IEC947-4-3, EN61000-4-3 10 V/m (80 MHz to 1 GHz)</td> </tr> <tr> <td>Immunity</td> <td>EFT</td> <td>IEC947-4-3, EN61000-4-4 2 kV AC power-signal line</td> </tr> <tr> <td>Immunity</td> <td>Surge transient</td> <td>IEC947-4-3, EN61000-4-5 2 kV</td> </tr> <tr> <td>Immunity</td> <td>RF disturbance</td> <td>IEC947-4-3, EN61000-4-6 10 V (0.15 to 80 MHz)</td> </tr> <tr> <td>Immunity</td> <td>Dips</td> <td>IEC947-4-3, EN61000-4-11</td> </tr> </table>	Emission	ESD	EN55011 Group 1 Class B IEC947-4-3, EN61000-4-2 4 kV contact discharge 8 kV air discharge	Immunity	Electromagnetic	IEC947-4-3, EN61000-4-3 10 V/m (80 MHz to 1 GHz)	Immunity	EFT	IEC947-4-3, EN61000-4-4 2 kV AC power-signal line	Immunity	Surge transient	IEC947-4-3, EN61000-4-5 2 kV	Immunity	RF disturbance	IEC947-4-3, EN61000-4-6 10 V (0.15 to 80 MHz)	Immunity	Dips	IEC947-4-3, EN61000-4-11
Emission	ESD	EN55011 Group 1 Class B IEC947-4-3, EN61000-4-2 4 kV contact discharge 8 kV air discharge																		
Immunity	Electromagnetic	IEC947-4-3, EN61000-4-3 10 V/m (80 MHz to 1 GHz)																		
Immunity	EFT	IEC947-4-3, EN61000-4-4 2 kV AC power-signal line																		
Immunity	Surge transient	IEC947-4-3, EN61000-4-5 2 kV																		
Immunity	RF disturbance	IEC947-4-3, EN61000-4-6 10 V (0.15 to 80 MHz)																		
Immunity	Dips	IEC947-4-3, EN61000-4-11																		

Engineering Data

Input Voltage vs. Input Current
Input Voltage vs. Input Impedance

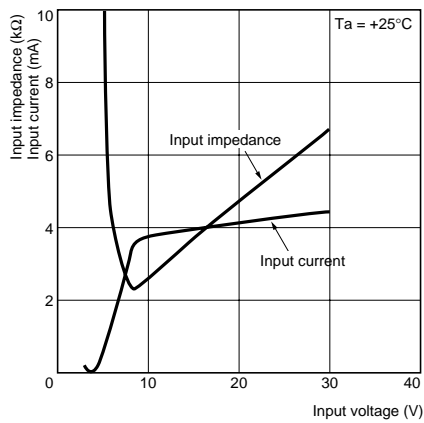

Load Current vs. Ambient Temperature

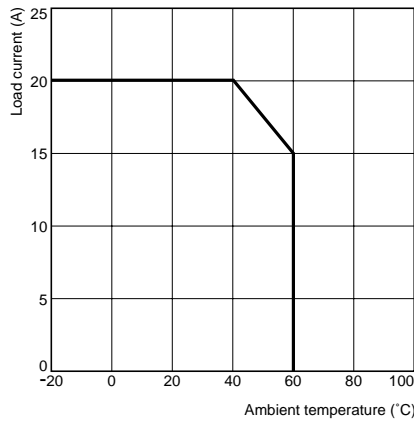

Inrush Current Resistivity (Non-repetitive Input)
The figure will be less than 1/2 for repetitive input.

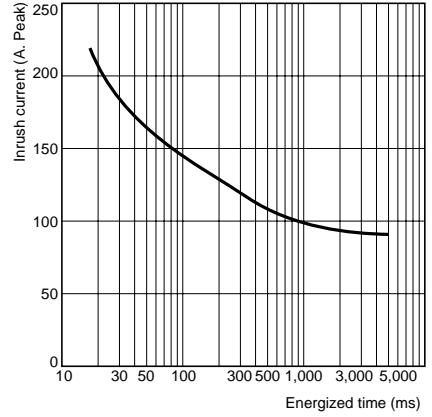

Operation

■ Failure Detection Function

Conditions for SSR Failure Detection

Failure mode (See note 1.)	Operating input (between terminals A1 and A2)	Detection time	Alarm display (See note 3.)	Alarm display (between terminals X1 and X2) (See note 3.)
SSR short-circuit	OFF	0.5 s max. (See note 2.)	Red	Open collector transistor output
SSR half-wave short-cir- cuit	OFF			
SSR open-circuit	ON			
SSR half-wave open-cir- cuit	ON			

- Note:**
- The contents of each of the above failure modes is as follows:
 SSR short-circuit: SSR output circuit remains in the ON state.
 SSR half-wave short-circuit: SSR output circuit remains in the ON state in one direction.
 SSR open-circuit: SSR output circuit remains in the OFF state.
 SSR half-wave open-circuit: SSR output circuit remains in the OFF state in one direction.
 In addition to the failure modes listed above, detection of circuit disconnections for the load circuit is also possible. (As a rough guide, circuit disconnection will be detected if the load impedance is greater than or equal to 1 MΩ.)
 - The same power supply is used for both the detection and for the output circuit and so detection is not performed during power interruptions.
 - If power supply (terminal 3) is in the open state, the SSR will still turn ON and OFF in the same way but the failure detection function and alarm display will not operate properly.

Connection Diagrams (Main Circuit)

The following diagrams show the applicable load connection configurations for SSR failure detection.

Single Phase

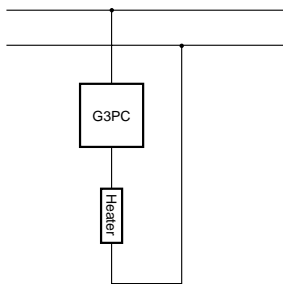

3-phase Star Connection

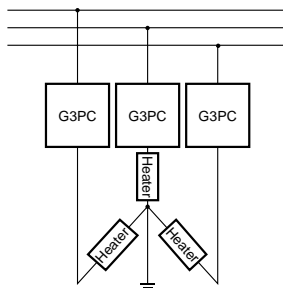

3-phase Delta Connection (3-phase, 2-wire Switching)

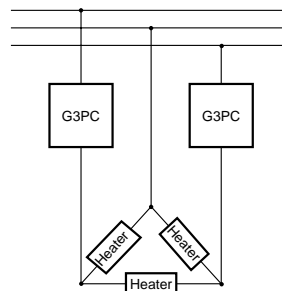

3-phase V Connection

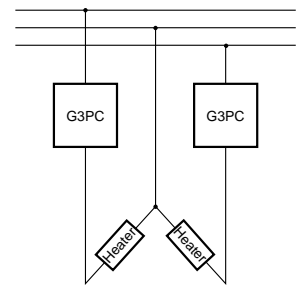

Note With 3-phase connection, so that the power supply voltage is applied between the G3PC's terminals 1/L1 and 3, connect the desired phase to terminal 3.

Timing Chart

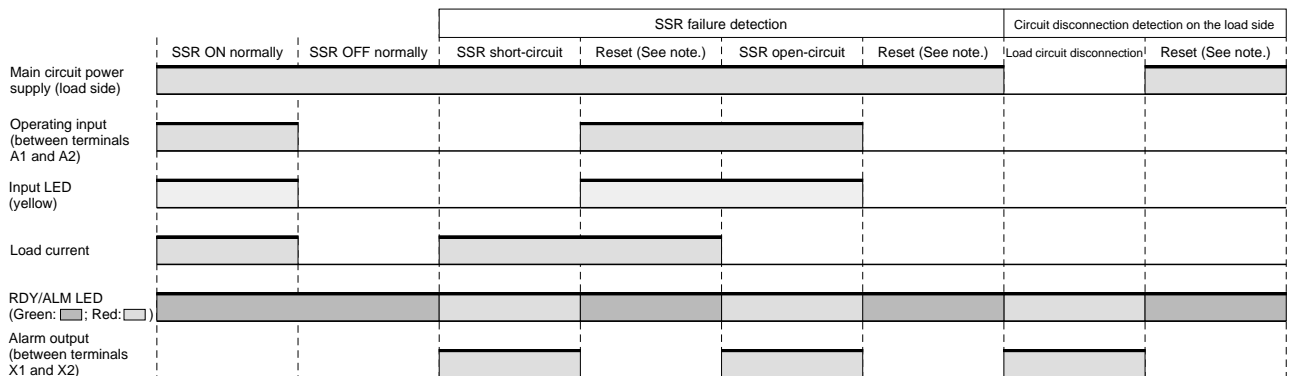

Note After failure detection, if the detection conditions differ to the conditions given under *Conditions for SSR Failure Detection*, alarm output is reset.

Dimensions

G3PC-220B-VD

Mounting Holes

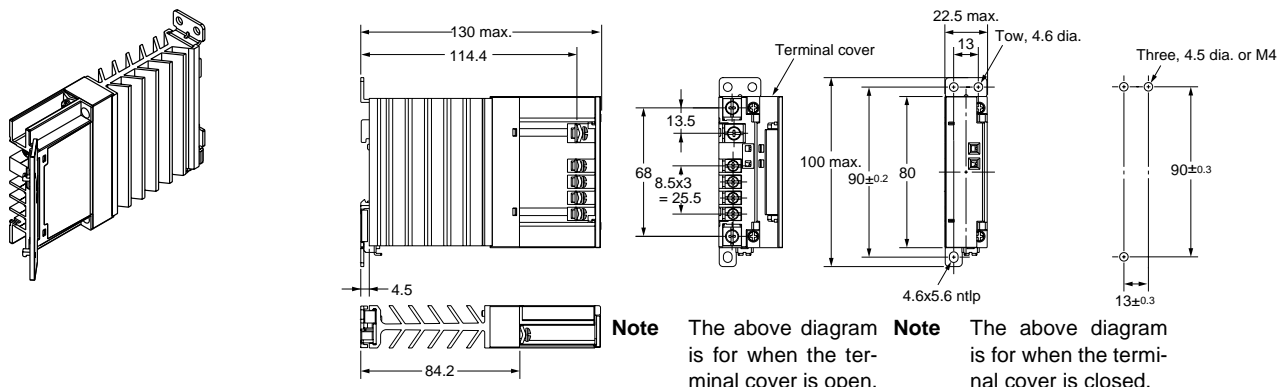

Accessories (Order Separately)

Mounting Tracks

PFP-100N, PFP-50N

PFP-100N2

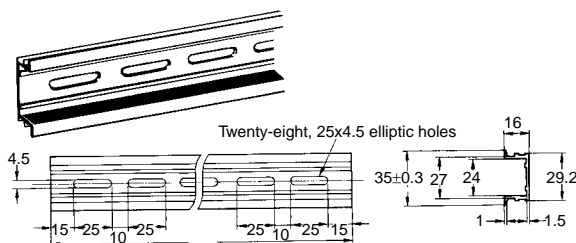
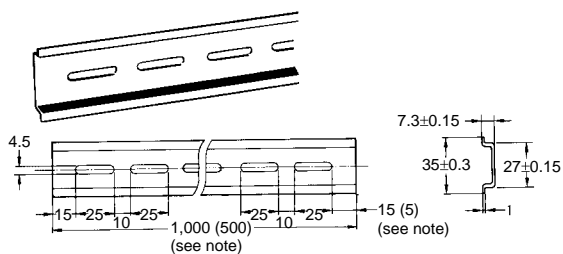

Note Values in parentheses indicate dimensions for the PFP-50N.

Installation

External Specifications

Terminal Arrangement

Terminal name	Terminal number	Screw size
Main circuit terminals (output)	1/L1, 2/T1	M4
Detection power supply terminal (input)	3	
Operating circuit terminals (input)	A1, A2	M3.5
Alarm output terminals (output)	X1, X2	

Indicators

Name	Symbol	Color	Meaning
Status indicators	RDY	Green	SSR normal
	ALM	Red	SSR failure detection and circuit disconnection detection
Input indicator	INPUT	Yellow	Operating

Note The same indicator is used as both the power supply indicator and the alarm indicator.

Appearance

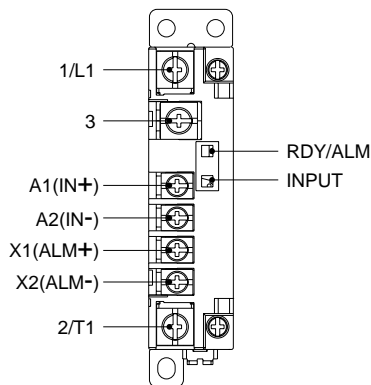

■ Connection Example

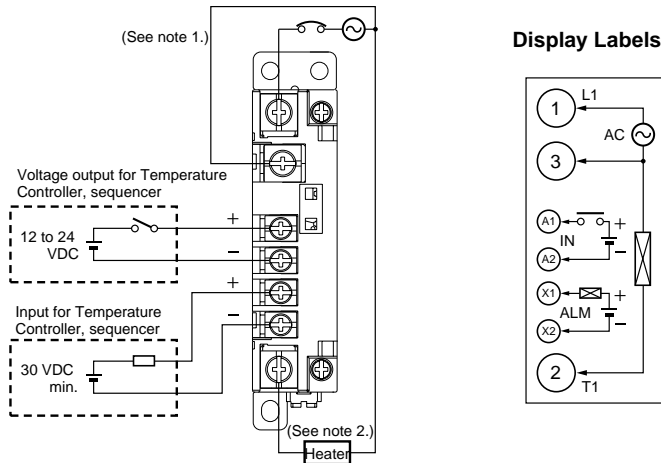

- Note:**
1. If the detection power supply terminal (terminal 3) is not connected, failure detection is not performed and so be sure to connect this terminal.
 2. If the load is connected to terminal 1/L1, failure detection may not operate correctly and so connect the load to terminal 2/T1.
 3. With inductive loads (relay coil, etc.), connect back-current prevention diodes to both sides of the load.

Precautions

— ! WARNING —

Do not touch the terminals (i.e., charged parts) of the G3PC while power is supplied. Doing so may result in electric shock. If the G3PC is provided with a terminal cover, be sure to attach the terminal cover to the G3PC before operating the G3PC.

— ! WARNING —

The G3PC and radiator are very hot while power is supplied to the G3PC.

Do not touch the G3PC or the radiator while power is supplied to the G3PC or immediately after the G3PC is turned OFF. Doing so may result in burns.

— ! WARNING —

Do not touch the main circuit terminal of the G3PC immediately after the G3PC is turned OFF, otherwise an electric shock may be received due to the residual charge of the built-in snubber circuit.

— ! WARNING —

Be sure to turn OFF the power supply to the G3PC before wiring, otherwise an electric shock may be received. Mount the terminal cover to the G3PC after wiring. Do not touch the terminals of the G3PC while power is supplied. Doing so may result in electric shock.

— ! WARNING —

Ensure that a short-circuit current does not flow on the load side of the SSR, otherwise the G3PC may be damaged.

■ General Precautions

At OMRON, we are constantly working to improve the quality and reliability of our products. SSRs, however, use semiconductors, which are prone to malfunction. Be sure to use SSRs within their rated value.

Use the SSR only in systems that are designed with redundancies, flame protection, counter measures to prevent operation errors, and other countermeasures to prevent accidents involving human life or fires.

1. Do not apply voltages or currents to the G3PC's terminals in excess of the rated values. Doing so may result in malfunction or burning.

2. Do not use the G3PC with terminal screws not properly tightened. Abnormal heating of the terminals may result in burning.
3. Do not obstruct the flow of air around the G3PC and the radiator. Abnormal heating of the G3PC may result in short-circuiting of output elements and burning.
4. Perform wiring and tighten screws according to the instructions given under *Correct Use*. Using the G3PC with incorrect wiring or with the screws not tightened properly may result in burning due to abnormal heating of the G3PC during use.

■ Correct Use

Before Actual Operation

1. In actual operation, the G3PC may cause accidents that were unforeseeable at the theoretical stage. Therefore it is necessary to test the G3PC under a variety of conditions that are possible. As for the characteristics of the G3PC, it is necessary to consider the differences between G3PC Units.
2. The ratings in this datasheet are for testing in a temperature range of 15 to 30°C, a relative humidity range of 25% to 85%, and an atmospheric pressure range of 88 to 106 kPa. When testing operation, it is necessary to confirm correct operation not only with the actual load that will be used, but also at the same ambient conditions as for actual operation.

Mounting Method

DIN Track Mounting

When mounting to a DIN track, mount the G3PC until it clicks into place, otherwise it become loose during use and fall. Fix both ends with end plates.

Panel Mounting

When mounting directly to a panel, observe the following conditions:

Screw diameter: M4

Tightening torque: 0.98 to 1.47 N·m

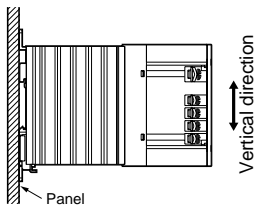
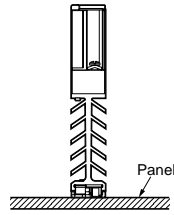
Vertical Mounting**Horizontal Mounting**

Note Use the G3PC at a load current of 50% of the rated load current when it is mounted horizontally.

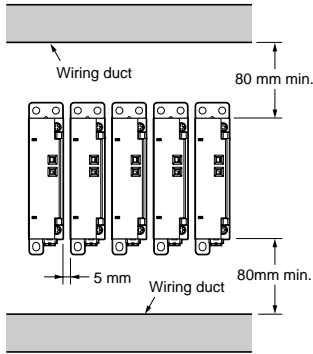
Side-by-side Mounting

Note Use the G3PC at a load current of 80% of the rated load current when it is mounted side-by-side.

Wiring

- When using crimp terminals, observe the terminal clearances shown below.

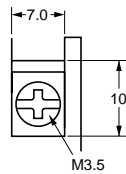
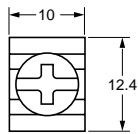
Main Circuit Power Supply (Terminals 1 to 3) Operating Input/Alarm Output (Terminals A1, A2, X1, and X2)

- Be sure that all lead wires are of a thickness appropriate for the current.
- The output terminals are charged, and touching them may result in electric shock, even when the G3PC is OFF. Separate the outputs from the power supply by installing a circuit-breaker at a higher level in the circuit.

Tightening Torque

Be sure to tighten the screws to the specified torques given below. Not doing so may result in malfunction.

Terminal number	Screw terminal diameter	Tightening torque
A1, A2, X1, X2	M3.5	0.59 to 1.18 N·m
2/L1, 2/T1, 3	M4	0.98 to 1.47 N·m

Operating Conditions

- Do not apply current exceeding the rated current. Otherwise, the temperature of the G3PC may rise excessively.
- Be sure to prevent the ambient temperature rising due to the heat radiation of the G3PC. If the G3PC is mounted inside a panel, install a fan so that the interior of the panel is fully ventilated.
- Do not use the G3PC if heat dissipation fins have been bent as a result of, for example, dropping the G3PC. If used in this state, the G3PC may be damaged due to the decreased heat dissipation capacity.
- Only use the G3PC with loads that are within the rated values. Using the G3PC with loads outside the rated values may result in malfunction, damage, or burning.

- Use a power supply within the rated frequency range. Using a power supply outside the rated frequency range may result in malfunction, damage, or burning.
- Keep wiring separate from high-voltage power lines and use wires of an appropriate length, otherwise malfunction and damage may result due to induction.
- As protection against accidents due to short-circuiting, be sure to install protective devices, such as fuses and NF breakers on the power supply side.

■ Operating and Storage Environments**1. Operating Ambient Temperature**

The rated value for the ambient operating temperature of the G3PC is for when there is no built-up heat. For this reason, under conditions where heat dissipation is not good due to poor ventilation, and where heat may build up easily, the actual temperature of the G3PC may exceed the rated value resulting in malfunction or burning.

When using the G3PC, design the system to allow heat dissipation sufficient to stay below the *Load Current vs. Ambient Temperature* characteristic curve. Note also that the ambient temperature of the G3PC may increase as a result of environmental conditions (e.g., climate, air-conditioning) and operating conditions (e.g., mounting in an airtight panel).

2. Operating and Storage Locations

Do not use or store the G3PC in the following locations. Doing so may result in damage, malfunction, or deterioration of performance characteristics.

- Do not use or store in locations subject to direct sunlight.
- Do not use in locations subject to ambient temperatures outside the range -20 to 60°C.
- Do not use in locations subject to relative humidity outside the range 45% to 85% or locations subject to condensation as the result of severe changes in temperature.
- Do not store in locations subject to ambient temperatures outside the range -30 to 70°C.
- Do not use or store in locations subject to corrosive or flammable gases.
- Do not use or store in locations subject to dust (especially iron dust) or salts.
- Do not use or store in locations subject to shock or vibration.
- Do not use or store in locations subject to exposure to water, oil, or chemicals.

3. Transportation

When transporting the G3PC, observe the following points. Not doing so may result in damage, malfunction, or deterioration of performance characteristics.

- Do not drop the G3PC or subject it to severe vibrations or shock.
- Do not transport the product if it is wet.

4. Vibration and Shock

Do not subject the SSR to excessive vibration or shock. Otherwise the SSR may malfunction and internal components may be damaged.

To prevent the SSR from abnormal vibration, do not install the G3PC in locations or by means that will subject it to the vibrations from other devices, such as motors.

5. Solvents

Do not allow the G3PC to come in contact with solvents such as thinners or gasoline. Doing so will dissolve the markings on the SSR.

6. Oil

Do not allow the G3PC terminal cover to come in contact with oil. Doing so will cause the cover to crack and become cloudy.

■ Operation

1. Leakage Current

A leakage current flows through a snubber circuit in the G3PC even when there is no input. Therefore, always turn OFF the power to the input or load and check that it is safe before replacing or wiring the G3PC.

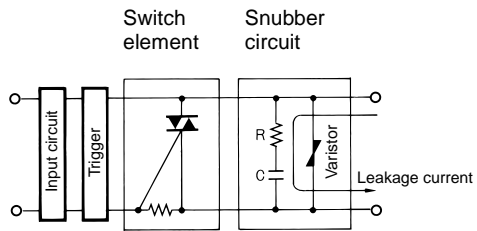

2. Screw Tightening Torque

Tighten the G3PC terminal screws properly. If the screws are not tight, the G3PC will be damaged by heat generated when the power is ON.

3. Mounting

Do not perform mounting with oil or metal powder on your hands. Doing so may result in damage to the G3PC.

4. Dropping

Be careful not to drop the G3PC during mounting. The G3PC weighs approximately 300 g and could cause injury if dropped on any part of your body.

ALL DIMENSIONS SHOWN ARE IN MILLIMETERS.

To convert millimeters into inches, multiply by 0.03937. To convert grams into ounces, multiply by 0.03527.

Cat. No. J127-E1-1

In the interest of product improvement, specifications are subject to change without notice.

OMRON Corporation

Industrial Automation Company

Industrial Devices and Components Division H.Q.

Industrial Control Components Department

Shiokoji Horikawa, Shimogyo-ku

Kyoto, 600-8530 Japan

Tel: (81)75-344-7119/Fax: (81)75-344-7149

Printed in Japan

0301-2M (0301) (O)