

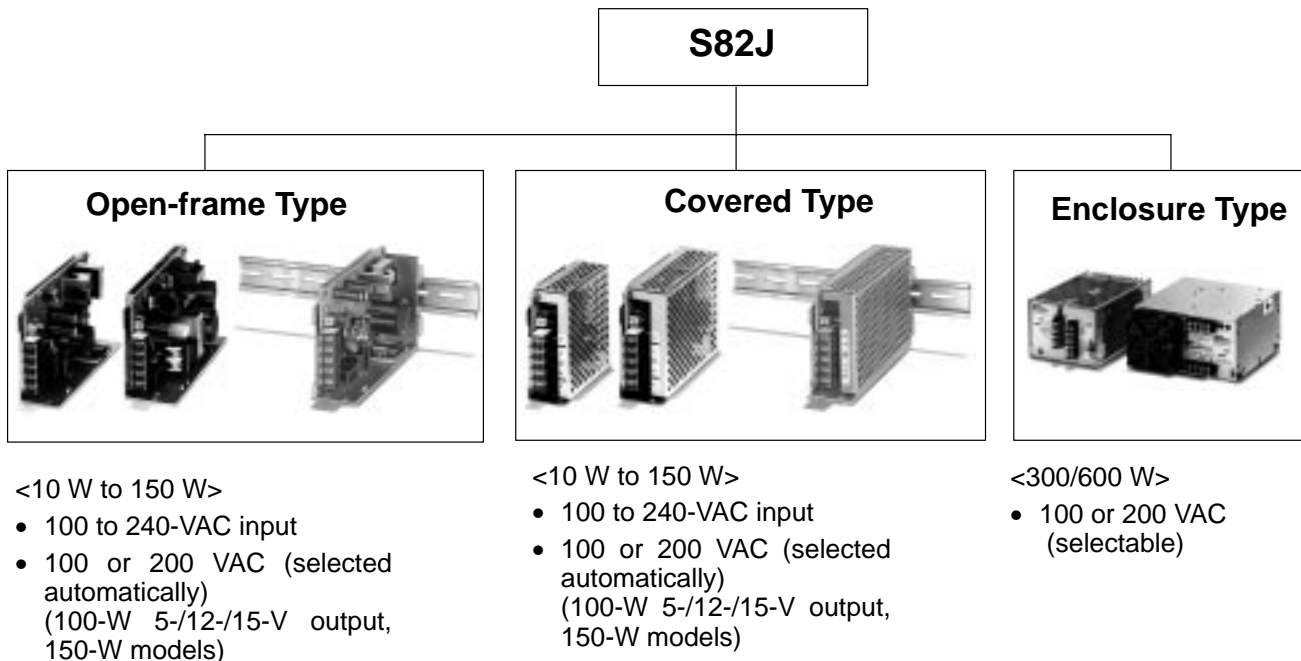



### Compact and Economical Switching Power Supplies with Capacities Up to 600 W DIN Track Mounting Bracket Type Now Available

- Power range from 10 W up to 600 W.
- Output Voltages: 5 V, 12 V, 15 V, or 24 V.
- Wide AC input range
  - 10-/25-/50-/100-W, 24-V output models: 100 to 240 VAC on one body
  - 100-W, 5-/12-/15-V output and 150-W models: 100 or 200 VAC selected automatically
  - 300-/600-W models: 100 or 200 VAC selectable
- Top terminal- and connector-type available with specific models in addition to front terminal type.
- Mounting bracket provided for mounting to control panels.
- Maintenance-free up to 300 W due to natural ventilation.
- Protection-ON alarm indicator shows valuable protection functions in action (300-/600-W models).
- Conforms to EMC standards: EN50081-2 and EN50082-2.
- With an external filter, achieves conformance to EN50081-1 for universal usage on EMI (300-/600-W models).
- Finger protection terminal block to meet VDE0106/P100
- Class 2 approved (10-/25-/50-W models)
- UL508 approved. All models can be used at full load in UL508A industrial control panel applications.
- Approved by UL/CSA standards, EN60950, and EN50178 (VDE0160).
- Six-language instruction manual provided. (English, French, German, Italian, Spanish, and Japanese)





# Ordering Information

## ■ Front-mounting Bracket Type

Configuration	Input Voltage	Power ratings	Output voltage	Output current	Front terminals 	Top terminals 	Connector 	
Open-frame type	100 to 240 VAC	10 W	5 V	2 A	S82J-01005A	---	---	
			12 V	1 A	S82J-01012A	---	---	
			15 V	0.7 A	S82J-01015A	---	---	
			24 V	0.5 A	S82J-01024A	---	---	
		25 W	5 V	5 A	S82J-02505A	---	---	
			12 V	2.1 A	S82J-02512A	---	---	
			15 V	1.7 A	S82J-02515A	---	---	
			24 V	1.1 A	S82J-02524A	---	---	
		50 W	5 V	10 A	S82J-05005A	---	---	
			12 V	4.2 A	S82J-05012A	---	---	
			15 V	3.5 A	S82J-05015A	---	---	
			24 V	2.1 A	S82J-05024A	---	---	
	100 or 200 VAC (selected automatically)	100 W	5 V	20 A	S82J-10005A	S82J-10005B	S82J-10005C	
			12 V	8.5 A	S82J-10012A	S82J-10012B	S82J-10012C	
			15 V	7 A	S82J-10015A	S82J-10015B	S82J-10015C	
			24 V	4.5 A	S82J-10024A	---	---	
	100 to 240 VAC	150 W	24 V	6.5 A	S82J-15024A	S82J-15024B	S82J-15024C	
	Covered type	100 to 240 VAC	10 W	5 V	2 A	S82J-01005D	---	---
				12 V	1 A	S82J-01012D	---	---
				15 V	0.7 A	S82J-01015D	---	---
24 V				0.5 A	S82J-01024D	---	---	
25 W			5 V	5 A	S82J-02505D	---	---	
			12 V	2.1 A	S82J-02512D	---	---	
			15 V	1.7 A	S82J-02515D	---	---	
			24 V	1.1 A	S82J-02524D	---	---	
50 W			5 V	10 A	S82J-05005D	---	---	
			12 V	4.2 A	S82J-05012D	---	---	
			15 V	3.5 A	S82J-05015D	---	---	
			24 V	2.1 A	S82J-05024D	---	---	
100 or 200 VAC (selected automatically)		100 W	5 V	20 A	S82J-10005D	S82J-10005E	S82J-10005F	
			12 V	8.5 A	S82J-10012D	S82J-10012E	S82J-10012F	
			15 V	7 A	S82J-10015D	S82J-10015E	S82J-10015F	
			24 V	4.5 A	S82J-10024D	---	---	
100 to 240 VAC		150 W	24 V	6.5 A	S82J-15024D	S82J-15024E	S82J-15024F	
100 or 200 VAC (selectable)		300 W	24 V	14 A	S82J-30024	---	---	
					S82J-30024N	---	---	
		600 W	27 A	S82J-60024	---	---		
	S82J-60024N			---	---			

## ■ DIN Track Mounting Bracket Type

Configuration	Input Voltage	Power ratings	Output voltage	Output current	Front terminals 	Top terminals 	Connector 	
Open-frame type	100 to 240 VAC	10 W	5 V	2 A	S82J-01005AD	---	---	
			12 V	1 A	S82J-01012AD	---	---	
			15 V	0.7 A	S82J-01015AD	---	---	
			24 V	0.5 A	S82J-01024AD	---	---	
		25 W	5 V	5 A	S82J-02505AD	---	---	
			12 V	2.1 A	S82J-02512AD	---	---	
			15 V	1.7 A	S82J-02515AD	---	---	
			24 V	1.1 A	S82J-02524AD	---	---	
		50 W	5 V	10 A	S82J-05005AD	---	---	
			12 V	4.2 A	S82J-05012AD	---	---	
			24 V	2.1 A	S82J-05024AD	---	---	
		100 or 200 VAC (selected automatically)	100 W	5 V	20 A	S82J-10005AD	S82J-10005BD	S82J-10005CD
	12 V			8.5 A	S82J-10012AD	S82J-10012BD	S82J-10012CD	
	15 V			7 A	S82J-10015AD	S82J-10015BD	S82J-10015CD	
	24 V			4.5 A	S82J-10024AD	---	---	
	100 to 240 VAC							
	100 or 200 VAC (selected automatically)	150 W	24 V	6.5 A	S82J-15024AD	S82J-15024BD	S82J-15024CD	
	Covered type	100 to 240 VAC	10 W	5 V	2 A	S82J-01005DD	---	---
				12 V	1 A	S82J-01012DD	---	---
15 V				0.7 A	S82J-01015DD	---	---	
24 V				0.5 A	S82J-01024DD	---	---	
25 W			5 V	5 A	S82J-02505DD	---	---	
			12 V	2.1 A	S82J-02512DD	---	---	
			15 V	1.7 A	S82J-02515DD	---	---	
			24 V	1.1 A	S82J-02524DD	---	---	
50 W			5 V	10 A	S82J-05005DD	---	---	
			12 V	4.2 A	S82J-05012DD	---	---	
			24 V	2.1 A	S82J-05024DD	---	---	
100 or 200 VAC (selected automatically)			100 W	5 V	20 A	S82J-10005DD	S82J-10005ED	S82J-10005FD
		12 V		8.5 A	S82J-10012DD	S82J-10012ED	S82J-10012FD	
		15 V		7 A	S82J-10015DD	S82J-10015ED	S82J-10015FD	
		24 V		4.5 A	S82J-10024DD	---	---	
100 to 240 VAC								
100 or 200 VAC (selected automatically)		150 W	24 V	6.5 A	S82J-15024DD	S82J-15024ED	S82J-15024FD	

**Model Number Legend:**

S82J -

1            2            3            4

**1. Power Ratings**

010: 10 W  
025: 25 W  
050: 50 W  
100: 100 W  
150: 150 W  
300: 300 W  
600: 600 W

**2. Output Voltage**

05: 5 V  
12: 12 V  
15: 15 V  
24: 24 V

**3. Configuration**

A: Open-frame type, front terminals  
B: Open-frame type, top terminals  
C: Open-frame type, connector  
D: Covered type, front terminals  
E: Covered type, top terminals  
F: Covered type, connector  
N: Without Mounting Bracket  
None: Enclosure type, front terminals with Mounting Bracket

**4. Mounting Bracket**

None: Front-mounting Bracket Type  
D: DIN Track Mounting Bracket Type

# Specifications

## ■ Ratings/Characteristics

Item		100 to 240 VAC input				100 or 200 VAC (selected automatically)		100 or 200 VAC (selectable)		
		10 W	25 W	50 W	100 W (24 V)	100 W (5, 12, 15 V)	150 W	300 W	600 W	
Efficiency (typical)		67% min. (77% min. for 50-W, 24-V models)			83% min.	75.5% min.	82% min.			
Input	Voltage	100 to 240 VAC (85 to 264 VAC) 110 to 170 VDC (set the terminal (L) to + side) (see note1)				100 (85 to 132) or 200 (170 to 264) VAC (selected automatically)		100 (85 to 132) or 200 (170 to 253) VAC (selectable)		
	Frequency	50/60 Hz (47 to 450 Hz)								
	Current (see note 2)	100 VAC input	0.35 A max.	0.8 A max.	1.4 A max.	2.5 A max.	2.5 A max.	3.5 A max.	8 A max.	14 A max.
		200 VAC input	0.3 A max.	0.6 A max.	0.8 A max.	1.5 A max.	1.4 A max.	2.1 A max.	4 A max.	7 A max.
	Leakage current (see note 2)	100 VAC input	0.5 mA max.							
		200 VAC input	1 mA max.							
	Inrush current (25°C, cold start) (see note 2)	100 VAC input	25 A max.							30 A max.
		200 VAC input	50 A max.							60 A max.
Noise filter	Yes									
Output (see note 3)	Voltage adjustment range	±10% (adjustable with variable resistor (V. ADJ))								
	Ripple (see note 2)	2% (p-p) max.								
	Input variation influence	0.4% max.								
	Load variation influence	0.8% max. (with rated input, 10% to 100% load)								
	Temperature variation influence	0.05%/°C max. (with rated input and output)								
	Startup time	500 ms max. (up to 90% of output voltage at rated input and output)							300 ms max. (up to 90% of output voltage at rated input and output)	
	Hold time (see note 2)	20 ms min.								
Additional function	Overload protection	105% to 160% of rated load current, inverted L drop/intermittent operation type, automatic reset					105% min. of rated load current, inverted L drop type, automatic reset (For the 600-W model, the circuit will be shut OFF when the overload exceeds 5 ±3 s. Protection-ON alarm indicator lit (see note 4))			
	Overvoltage protection (see note 5)	No	Yes		Yes (5-V output models only)	No	Yes, protection-ON alarm indicator lit (see note 4)			
	Overheat protection	No							Yes, protection-ON alarm indicator lit (see note 4)	
	Protection-ON alarm indicator	No							Yes (color, red)	
	Parallel operation	No							Yes, 5 units max.	
Series operation	No			Yes						

Item		100 to 240 VAC input				100 or 200 VAC (selected automatically)		100 or 200 VAC (selectable)	
		10 W	25 W	50 W	100 W (24 V)	100 W (5, 12, 15 V)	150 W	300 W	600 W
Other	Ambient temperature	Operating: See the derating curve in the Engineering Data section. Storage: -25 to 65°C (with no condensation and icing)							
	Ambient humidity	Operating: 25% to 85% Storage: 25% to 90%							
	Dielectric strength	3.0 kVAC, 50/60 Hz for 1 min (between all inputs and all outputs)							
		2.2 kVAC, 50/60 Hz for 1 min (between all inputs and all inputs/GR terminal)							
		1.0 kVAC, 50/60 Hz for 1 min (between all outputs and GR terminal)							
	Insulation resistance	100 MΩ min. (between all outputs and all inputs/GR terminals at 500 VDC)							
	Vibration resistance	10 to 55 Hz, 0.375-mm double amplitude for 2 h each in X, Y, and Z directions							
	Shock resistance	300 m/s <sup>2</sup> , 3 times each in ±X, ±Y, and ±Z directions							
	Terminal screw tightening	0.74 N • m				1.08 N • m			
	Output indicator	Yes (green)							
	Electromagnetic interference (see note 2)	Conforms to FCC Class A							
	EMC	Emission Enclosure: EN55011 class A Emission AC Mains: EN55011 class A Immunity ESD: EN61000-4-2: 4 kV contact discharge (level 2) 8 kV air discharge (level 3) Immunity RF-interference: ENV50140: 10 Vm (80 MHz to 1 GHz) (level 3) Immunity Conducted Disturbance: ENV50141: 10 V (0.5 to 80 MHz) (level 3) Immunity Burst: EN61000-4-4: 2 kV power-line (level 3) 2 kV output line (level 4)							
	EMC standards	Conforms to EN50081-2 and EN50082-2						Conforms to EN50081-2 and EN50082-2 (see note 6) With noise filter, confirms to EN50081-1 (see note 6 and 7)	
Approved standards	UL	UL508 (Listing), 1950, Class 2 (per UL1310)			UL508 (Listing), 1012, 1950 (see note 8)		UL508/1012		
	CSA	CSA C22.2 No. 14, No. 950, Class 2			CSA C22.2 No. 14, No. 950		CSA EB1402C		
	VDE	EN50178 (VDE0160) and EN60950 Terminal types (only terminal part): VDE0106/P100							
Weight (see note 9)	250 g max.	350 g max.	400 g max.	500 g max.	1,000 g max.		2,000 g max.	2,500 g max.	

- Note:**
- DC inputs not included in safety standard approvals.
  - At 100% load for rated input voltage (100 VAC or 200 VAC).
  - The output specification is defined at the power supply output terminals.
  - For resetting, turn OFF the power supply, leave for more than three minutes, and then turn ON the power supply.
  - For resetting, turn OFF the power supply, leave for more than one minutes (90 seconds min. for the 300-W models and 3 minutes min. for the 600-W models), and then turn ON the power supply.
  - To ensure the Emission Enclosure rating ferrite ring cores (recommended model: S82Y-JC-T) should be used on all cabling.
  - To ensure the Emission AC Mains rating for EN50081-1 (only for 200-VAC input), a noise filter (recommended models: S82Y-JF3-N for 300-W, S82Y-JF6-N for 600-W) should be used on the input lines.
  - With UL508, 150-W connector type has "Recognized" approval.
  - The weight indicated is the weight of the open-frame type. (Includes the covers for 300-W and 600-W models)

## ■ Reference Value

Item	Value	Definition
Reliability (MTBF)	135,000 hours min.	MTBF stands for Mean Time Between Failures, which is calculated according to the probability of accidental device failures, and indicates reliability of devices. Therefore, it does not necessarily represent a life of the product.
Life expectancy	10 yrs. min.	The life expectancy indicates average operating hours under the ambient temperature of 40°C and a load rate of 50%. Normally this is determined by the life expectancy of the built-in aluminum electrolytic capacitor.

# Engineering Data

## Derating Curve

### 10-/25-/50-/100-/150-W Model

#### Open-frame type

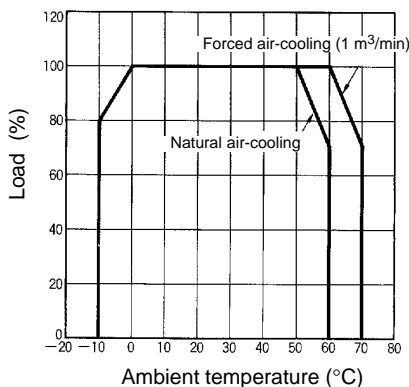

#### Covered-type

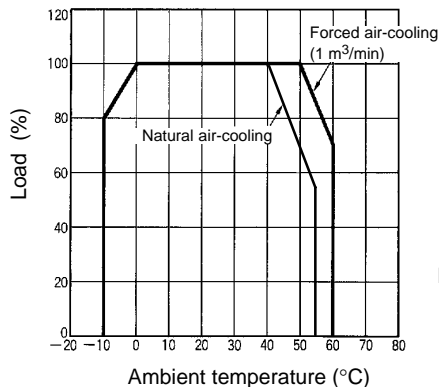

#### Standard Installation

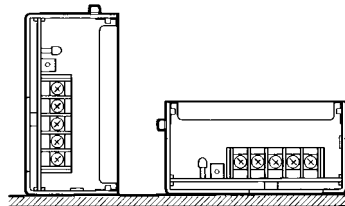

**Note:** The derating curve shown is for standard installation. The derating curve depends on the mounting direction of the Power Supply.

### 300-W Model

#### Single Operation

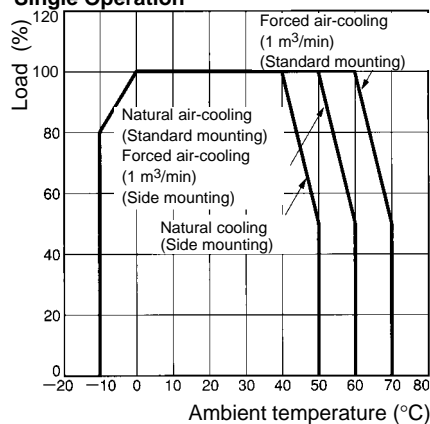

#### Parallel Operation

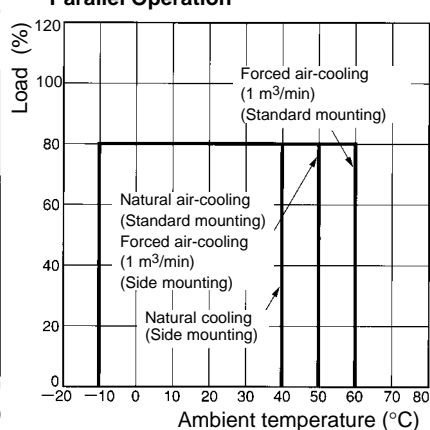

#### Standard mounting

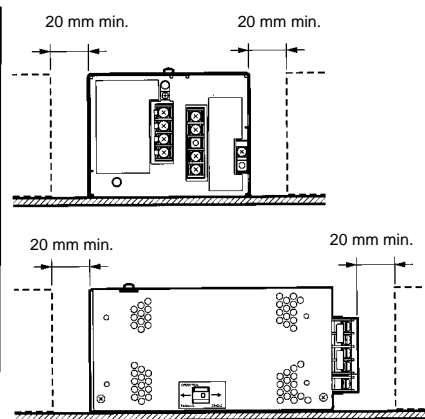

### 600-W Model

#### Single Operation

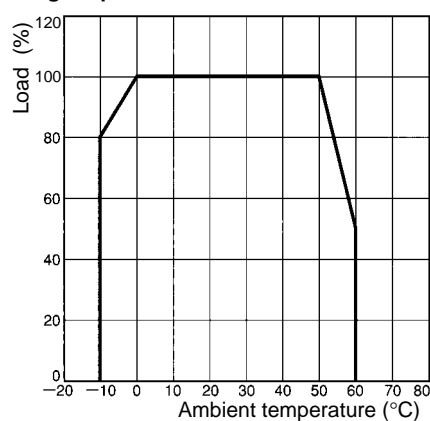

#### Parallel Operation

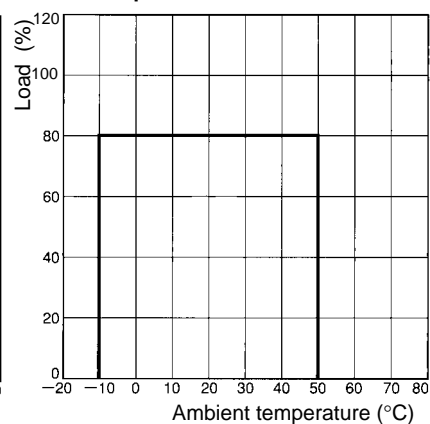

#### Standard Mounting

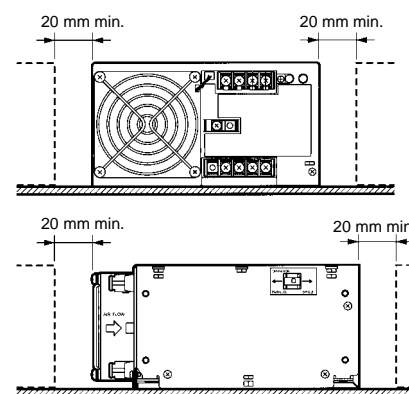

**Note:** Provide a minimum clearance of 20 mm between the Power Supplies.

**■ Overload Protection**

**10- to 300-W Models**

The Power Supply is provided with an overload protection function that protects the load and the power supply from possible damage by overcurrent. When the output current rises above 105% to 160% of the rated output current (105% of the rated output current for 300-W models), the protection function is triggered, decreasing the output voltage. When the output current falls within the rated range, the overload protection function is automatically cleared.

**10- to 300-W Models  
(except for 50-W and  
100 (24 V)-W Models)**

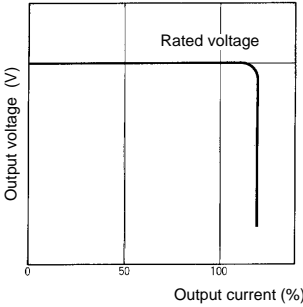

**50-W and  
100 (24 V)-W Models**

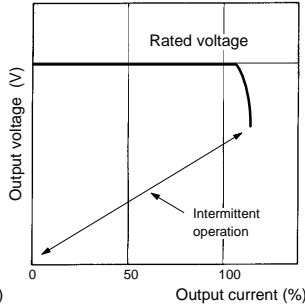

**600-W Models**

If an excessive current flows for 5 s or more, the output will be turned off and simultaneously protection-ON alarm indicator will be lit. To reset the S82J, turn off the input voltage, leave the S82J for at least three minutes, and then apply the input voltage again.

**Note:** Do not continue using the S82J with the output terminals short-circuited or the overcurrent condition continued, otherwise the internal elements of the S82J may be damaged or broken.

**■ Overvoltage Protection**

**100 (5, 24 V)-W Models**

The Power Supply is provided with an overvoltage protection function that protects the load and the Power Supply from possible damage by overvoltage. When the output voltage rises above a set value (120% of the rated output voltage), the protection function is triggered, shutting off the output voltage. If this occurs, reset the Power Supply by turning it off for 1 minutes min. and then turning it on again.

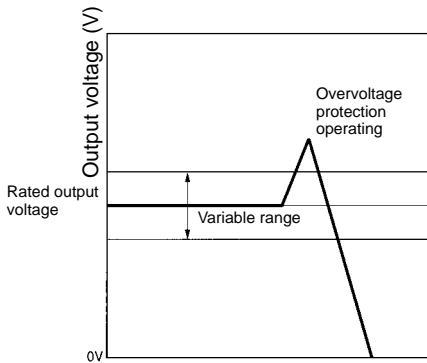

**300- and 600-W Models**

If a voltage that is 120% of the rated output voltage or above is output, the output voltage will be turned off and simultaneously protection-ON alarm indicator will be lit. To reset the S82J, turn off the input voltage, leave the S82J for at least three minutes if it is a 600-W model or at least 90 seconds if it is a 300-W model, and then apply the input voltage again.

**■ Overheat Protection Function**

**600-W Model Only**

If the internal temperature of the S82J rises excessively as a result of fan failure or any other reason, the overheat protection circuit will be triggered to protect the internal elements of the S82J and simultaneously a protection-ON alarm indicator will be lit. To reset the S82J, turn off the input voltage, leave the S82J for at least three minutes, and then apply the input voltage again.

**■ Inrush Current, Startup Time, Hold Time**

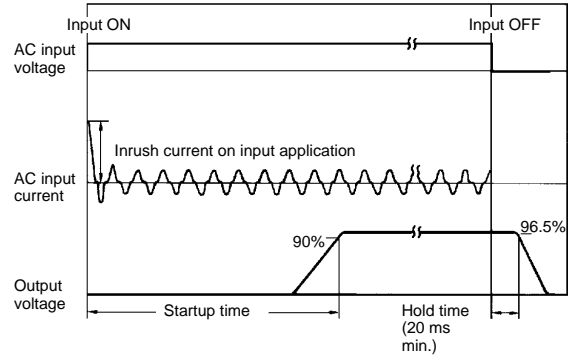



# Operation

## ■ Block Diagrams

S82J-010□□□□ (10 W)

S82J-025□□□□ (25 W)

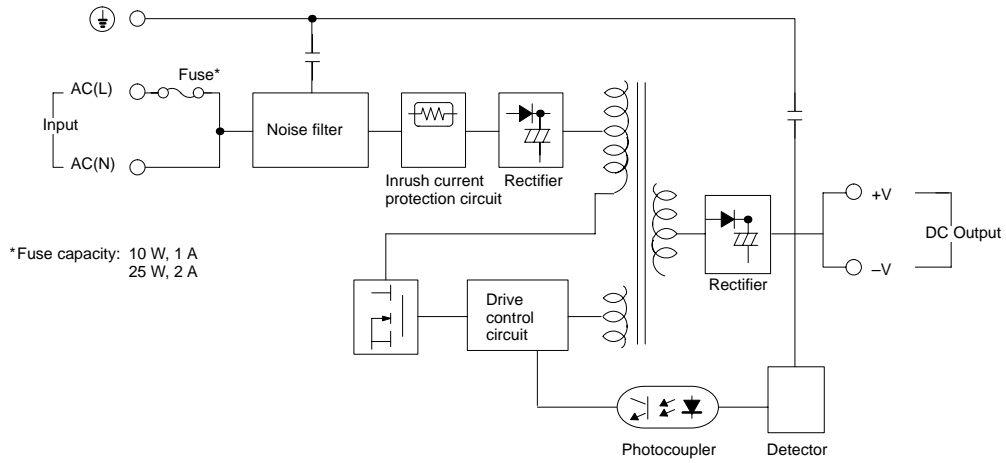

S82J-050□□□□ (50 W)

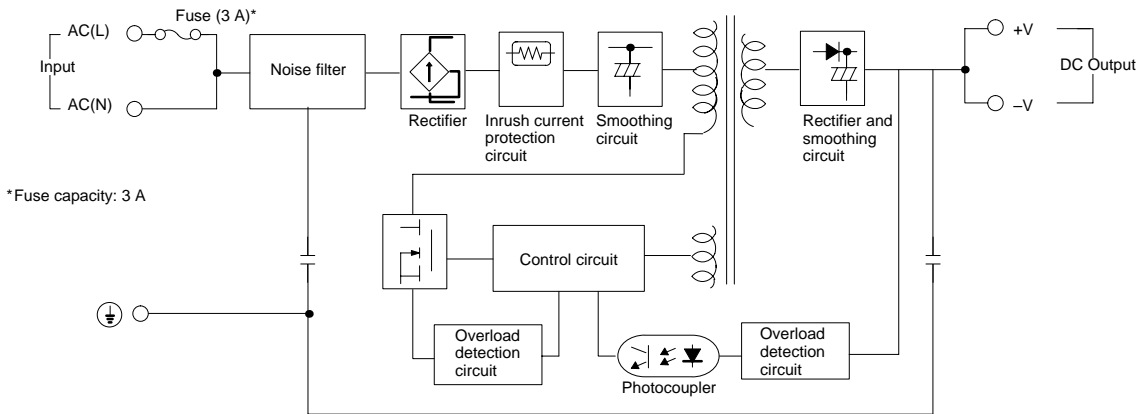

S82J-100□□□□  
(100 W, 5-/12-/15-V Output)

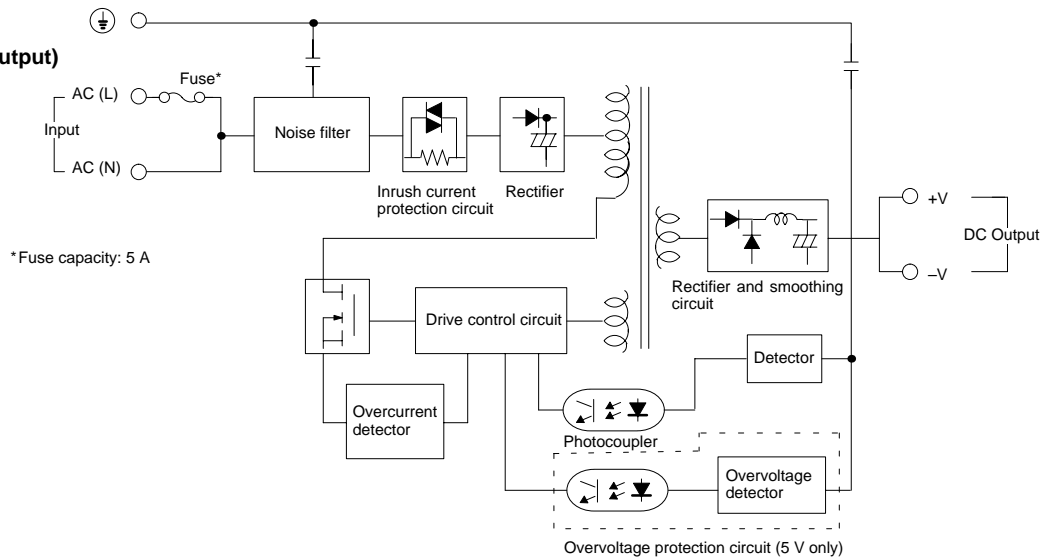

**S82J-10024□□ (100 W, 24-V Output)**

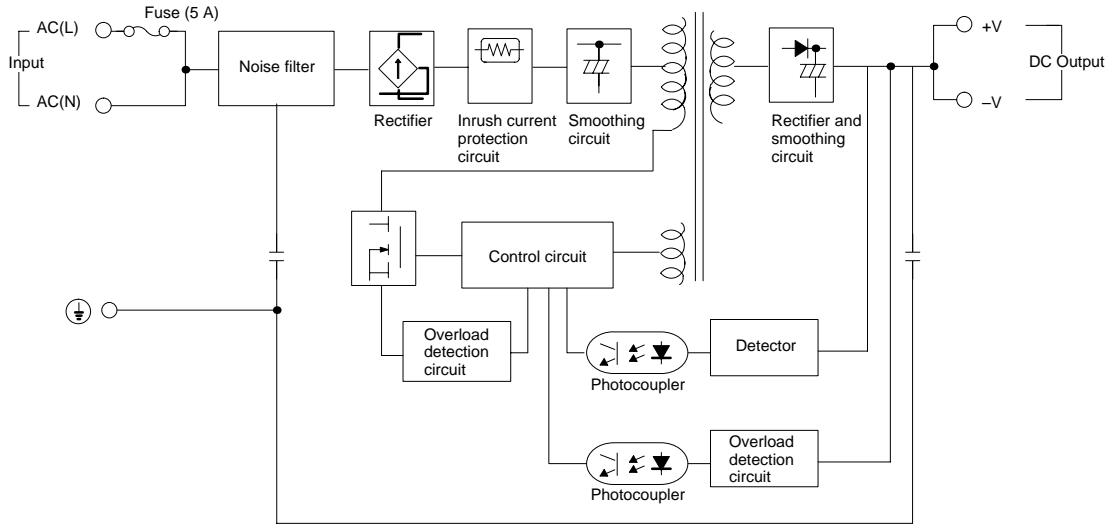

**S82J-15024□□ (150 W)**

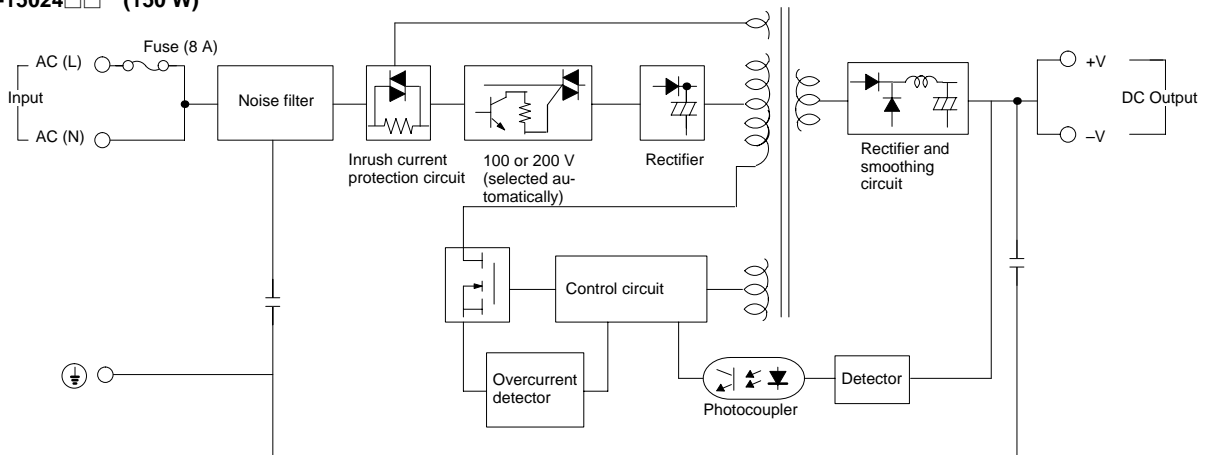

**S82J-30024□ (300 W)**

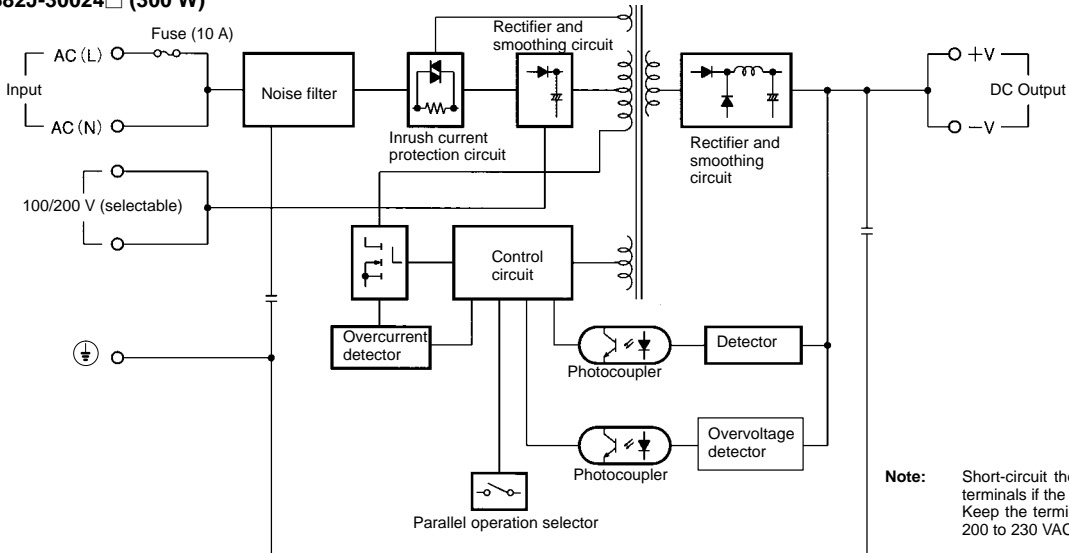

**Note:** Short-circuit the input voltage selector terminals if the input is 100 to 120 VAC. Keep the terminals open if the input is 200 to 230 VAC.

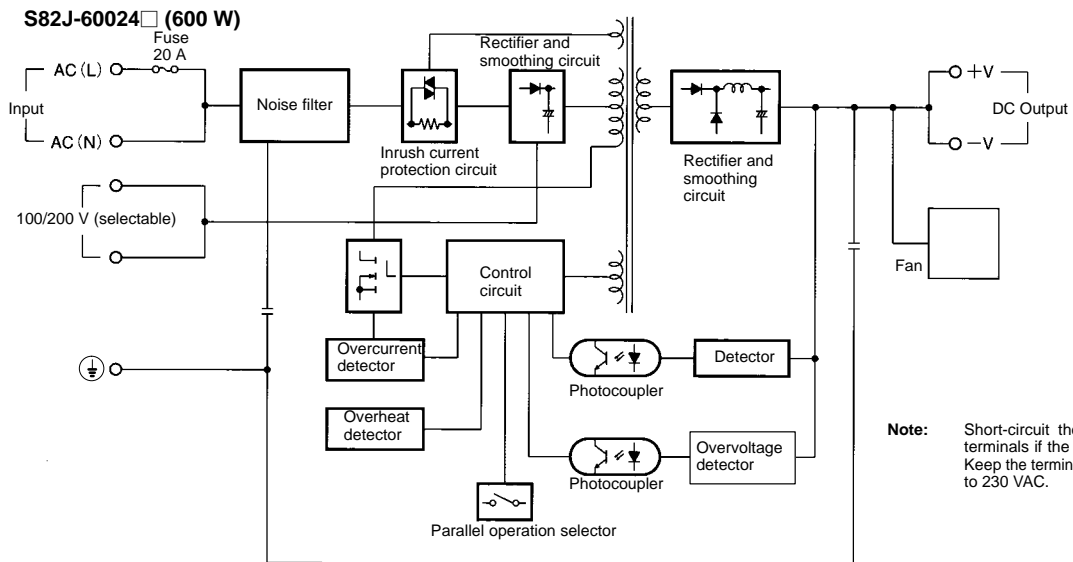

**Note:** Short-circuit the input voltage selector terminals if the input is 100 to 120 VAC. Keep the terminals open if the input is 200 to 230 VAC.

# Dimensions

Note: All units are in millimeters unless otherwise indicated.

## ■ Front-mounting Bracket Type

S82J-010□□□ (10 W)

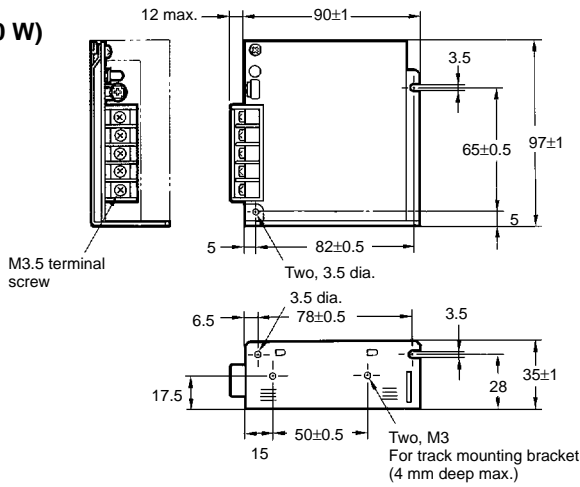
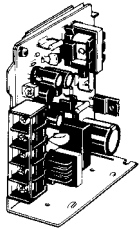

### Mounting Holes (Surface Screw Mounting)

#### Side Mounting

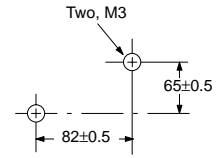

#### Bottom Mounting

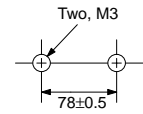

S82J-025□□□ (25 W)

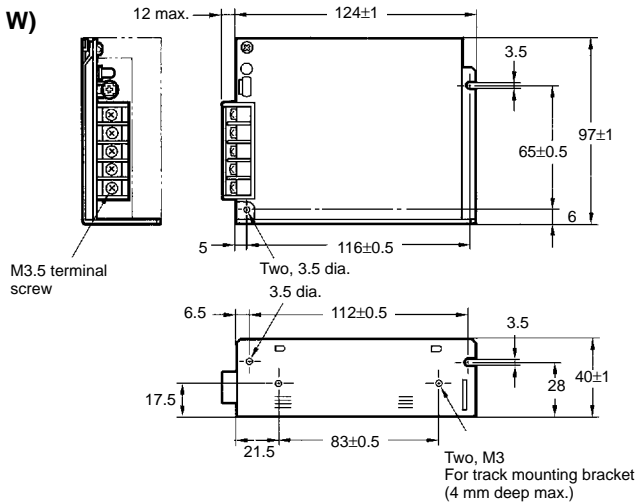
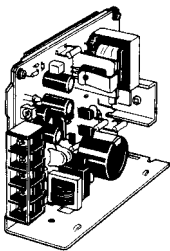

### Mounting Holes (Surface Screw Mounting)

#### Side Mounting

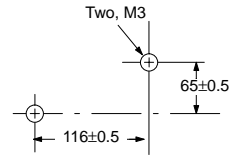

#### Bottom Mounting

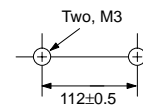

S82J-050□□□ (50 W)

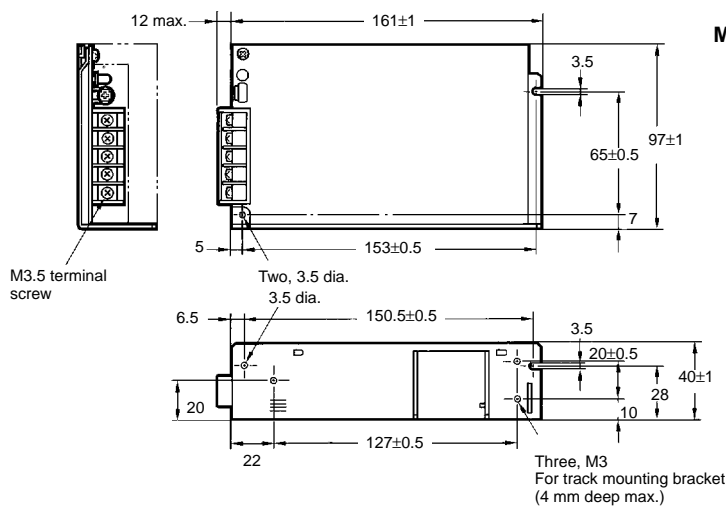
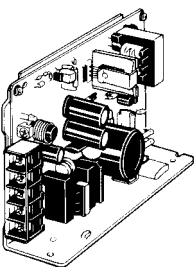

### Mounting Holes

#### Side Mounting

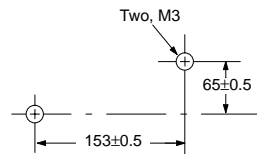

#### Bottom Mounting

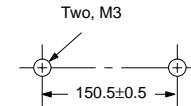

**S82J-10024** (100 W, 24-V Output)

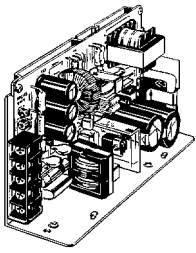

M3.5 terminal screw

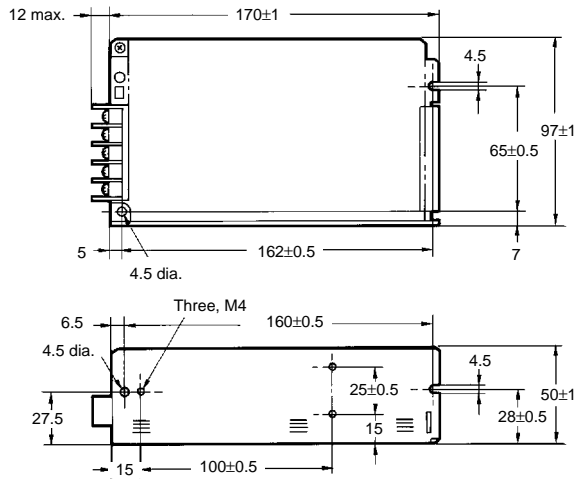

**Mounting Holes**

**Side Mounting**

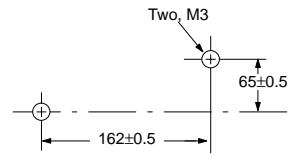

**Bottom Mounting**

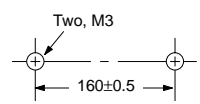

**S82J-100** (100 W, 5-/12-/15-V Output)  
**S82J-15024** (150 W)

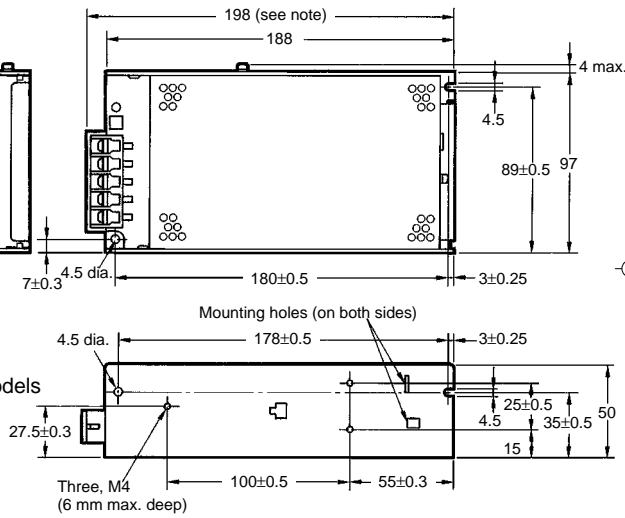
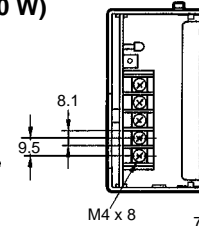
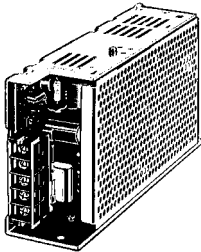

**Mounting Holes (Surface Screw Mounting)**

**Side Mounting**

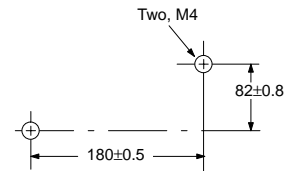

**Bottom Mounting**

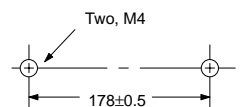

**Note:** Top terminal and connector models are 188 mm wide.

**S82J-30024** (300 W)

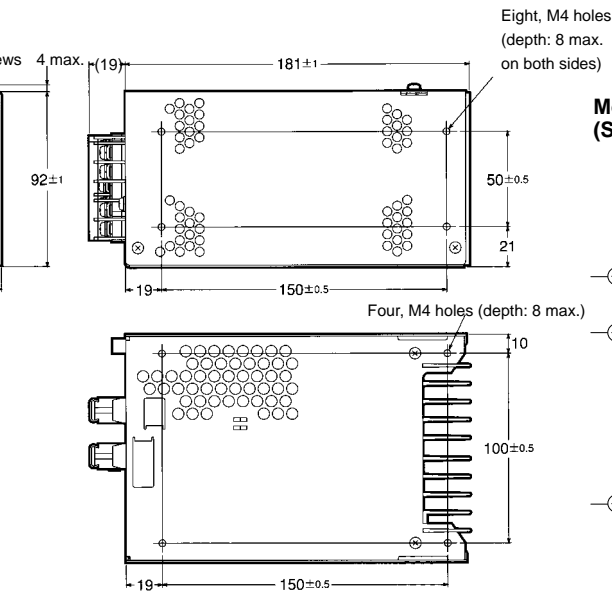
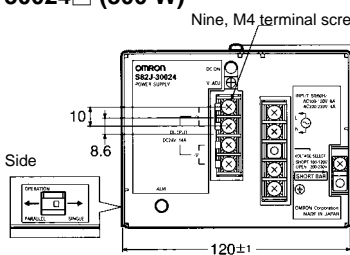
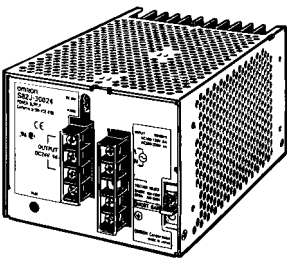

Eight, M4 holes (depth: 8 max. on both sides)

**Mounting Holes (Surface Screw Mounting)**

**Side Mounting**

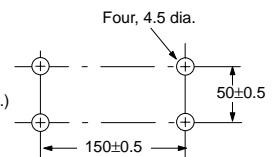

**Bottom Mounting**

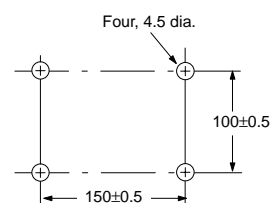

S82J-60024□ (600 W)

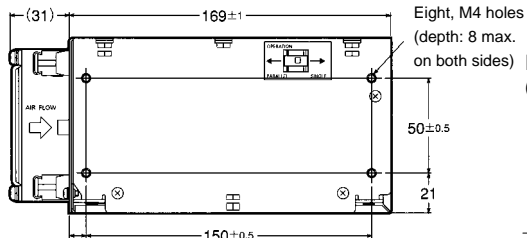
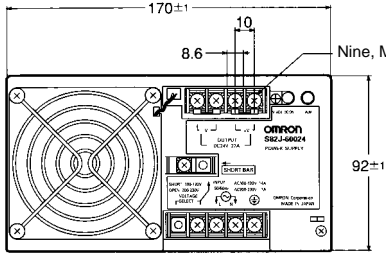
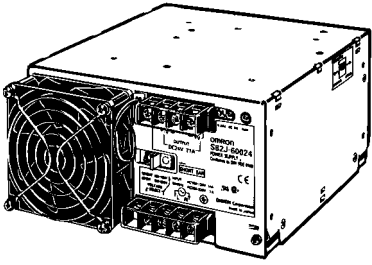

Mounting Holes (Surface Screw Mounting)

Side Mounting

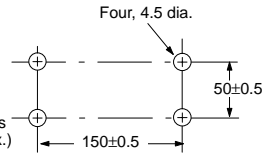

Bottom Mounting

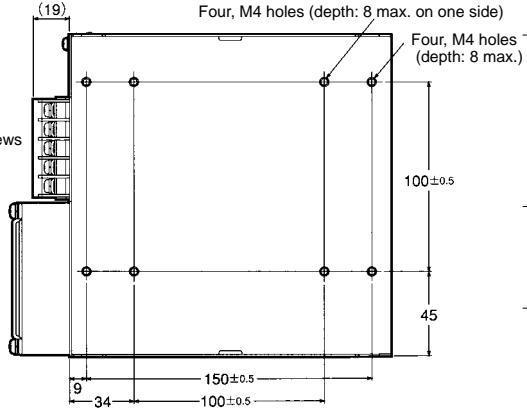
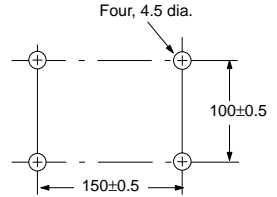

Dimensions with Mounting Bracket (Provided)

10-/25-/50-/100 (24 V)-W Models

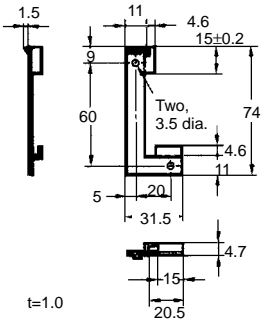

Mounting Holes

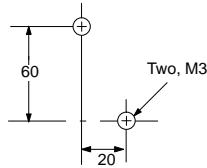

Using the Mounting Bracket

Attach the mounting bracket to the panel and loosely tighten the two screws. Insert the projected parts of the bracket (b) to the square holes of the power supply (a). Then securely tighten the screws.

**Note:** The mounting screws are order separately.

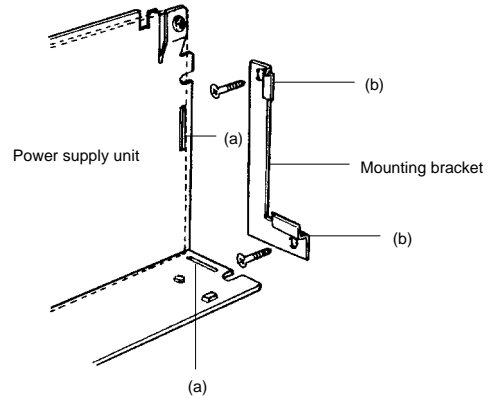

100- (5, 12, 15 V) and 150-W Models

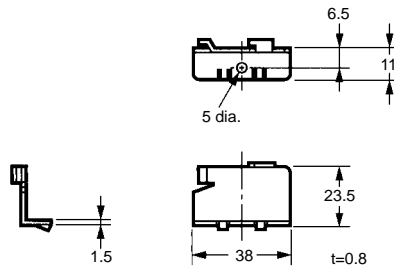
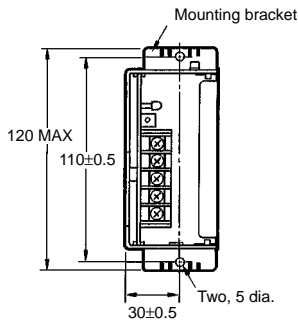

**Note:** The brackets are for front-mounting.

Mounting with Brackets

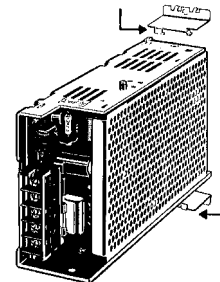

300-W Models

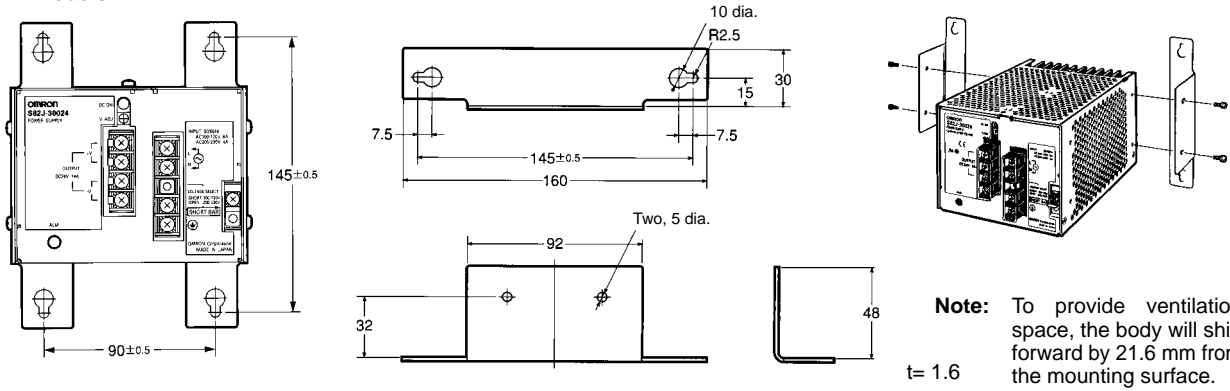

600-W Models

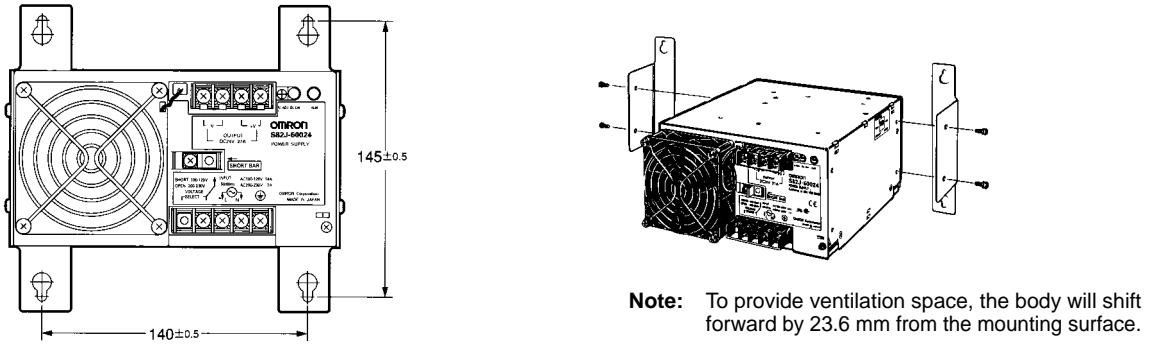

■ DIN Track Mounting Bracket Type

S82J-010□□□D (10 W)

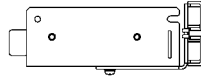
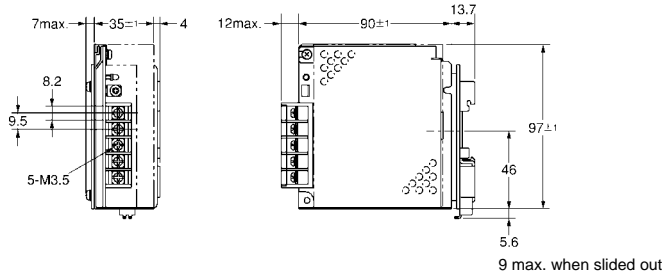
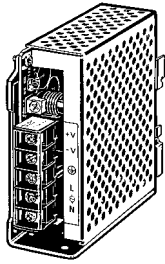

S82J-025□□□D (25 W)

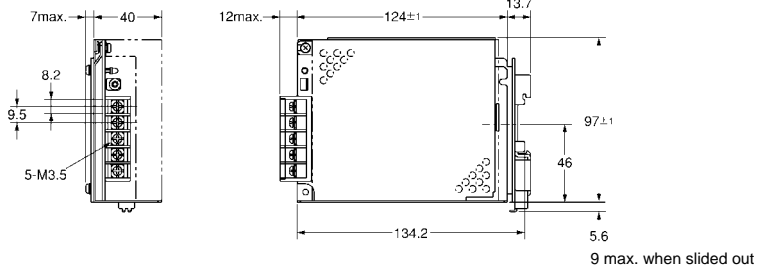
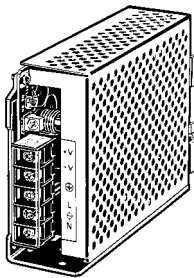

S82J-050□□□D (50 W)

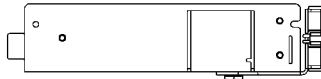
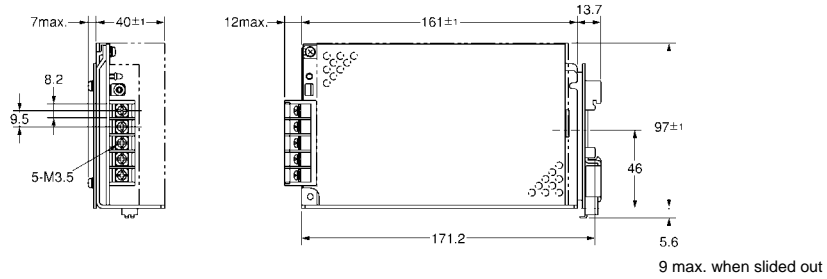
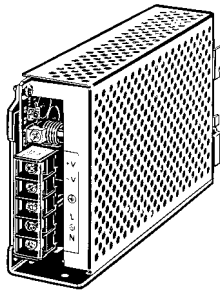

S82J-10024□D  
(100 W, 24-V Output)

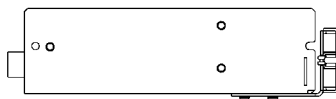
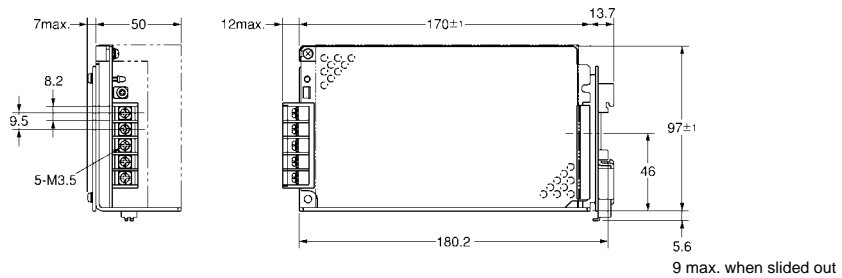
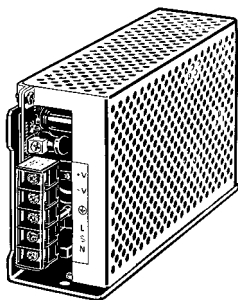



S82J-100□□□D (100 W, 5-/12-/15-V Output)  
 S82J-15024□□D (150 W)

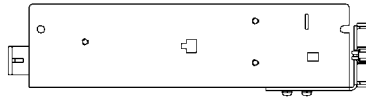
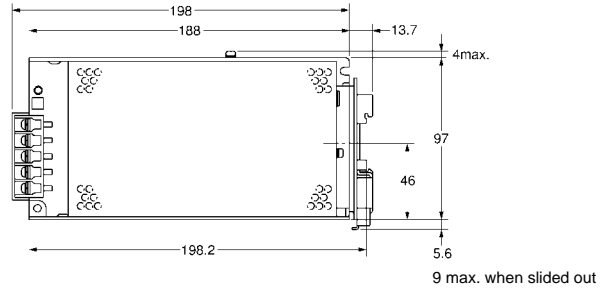
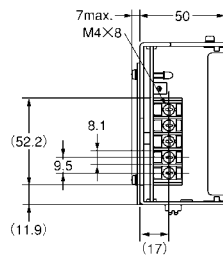
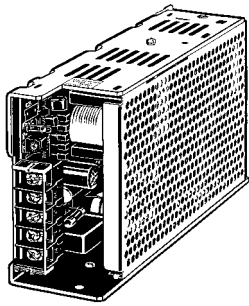

# Installation

## 10-/25-/50-/100-/150-W Models

**Note:** 10-/25-/50-/100 (24 V)-W models are available only as Front Terminal Models.

### Front Terminals Model

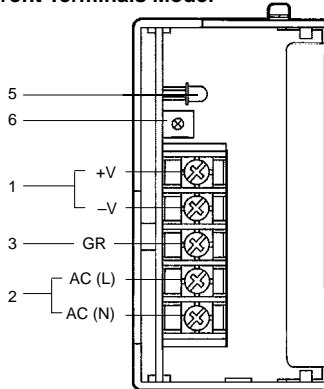

### Top Terminals Model

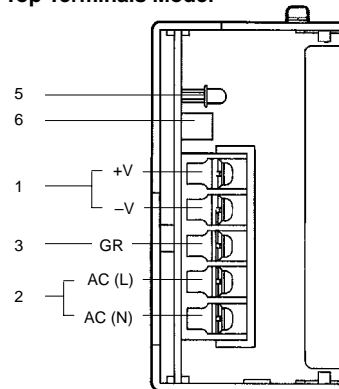

### Connector Model

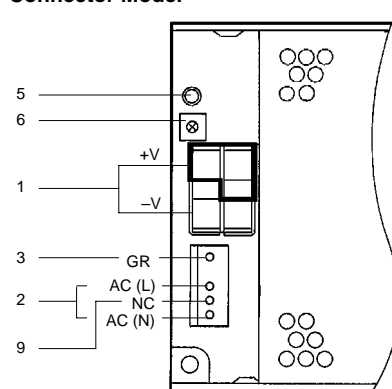

### Connectors

Connector	Connector on the PCB side	Housing	Terminal
Input	Wafer (Made by Molex) 5277-04A-RE	Housing (Made by Molex) 5196-04-RE or 5196-04	Terminal (Made by Molex) 5194T or 5194TL
Output	Tab header (Made by Nippon AMP) 1-178140-5	Rise housing (Made by Nippon AMP) 1-178129-6	Rise contact (Made by Nippon AMP) 1-175196-5 or 1-175218-5

**Note:** The permissible current of the output connector is 8 A per pin.

## 300-W Models

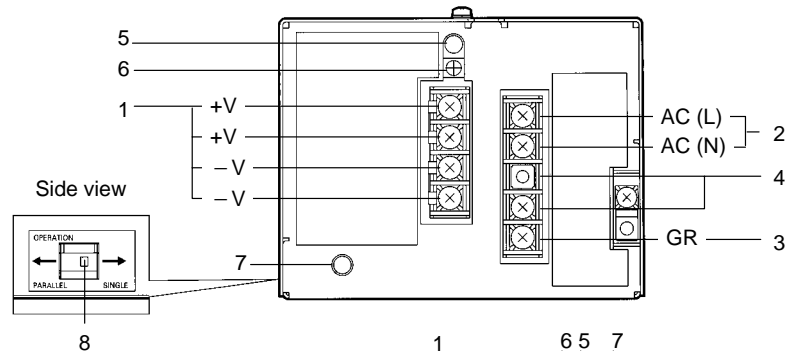

## 600-W Models

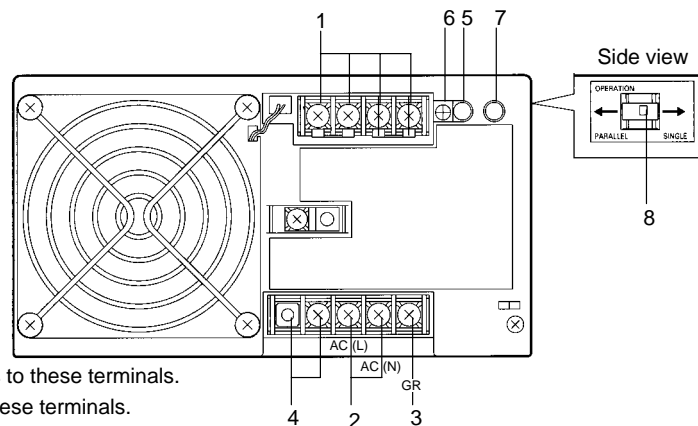

- DC Output Terminals:** Connect the load lines to these terminals.
- Input Terminals:** Connect the input lines to these terminals.  
**Note:** A fuse is inserted into the AC (L) side.
- Ground Terminal (GR):** Connect a ground line to this terminal.
- Input Voltage Selector Terminals:** Short-circuit the terminals if the input is 100 to 120 VAC and open the terminals if the input is 200 to 230 VAC
- Output Indicator (DC ON):** Lights while a Direct Current (DC) output is ON.
- Output Voltage Adjuster (V.ADJ):** It is possible to increase or decrease the output voltage by 10%.
- Protection-ON Alarm Indicator:** The red indicator will be lit if the overvoltage (for a 300-/600-W model) or overheat protection (for a 600-W model) circuit is triggered. This indicator will also be lit when overcurrent (for a 600-W model) is detected.
- Parallel/Single Operation Selector:** Set the selector to PARALLEL if the Units are in parallel operation.
- NC Terminals:** Leave unconnected.

## Precautions

### Mounting

To improve and maintain the reliability of the Power Supply over a long period of time, adequate consideration must be given to heat radiation.

The Power Supply is designed to radiate heat by means of natural air-flow. Therefore, mount the Power Supply so that air flow takes place around the Power Supply.

When mounting the Power Supply, mounting it to a metal plate is recommended.

When mounting two or more Power Supplies side-by-side, allow at least 20 mm spacing between them, as shown in the following illustration.

Forced air-cooling is recommended.

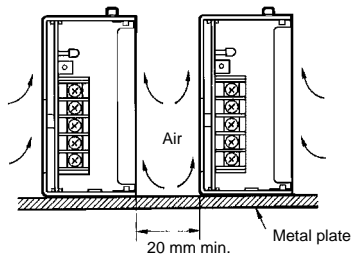

### Mounting Methods

The following mounting methods are available.

#### 10-/25-/50-/100 (24 V)-W Models

- (A) Side mounting
- (B) Bottom mounting
- (C) Front mounting (see *Accessories*)

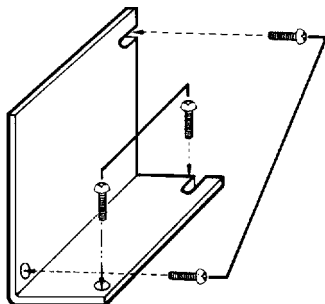

#### 100 (5, 12, 15 V)/150-/300-/600-W Models

- (A) Side mounting
- (B) Bottom mounting (secured with screws from the inside of the Switching Power Supply)
- (C) Bottom mounting (secured with screws from the back of the Switching Power Supply)

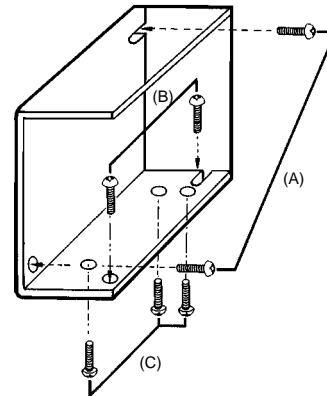

- (D) Front mounting  
Front mounting is possible with the mounting brackets provided. Refer to *Dimensions*.

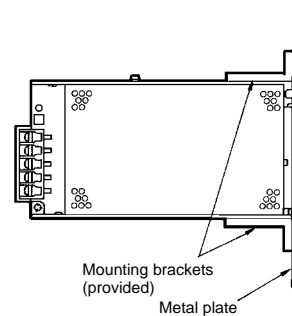

### Generating Output Voltage ( $\pm$ )

An output of  $\pm$  can be generated by using two Power Supplies as shown below, because the Power Supply produces a floating output.

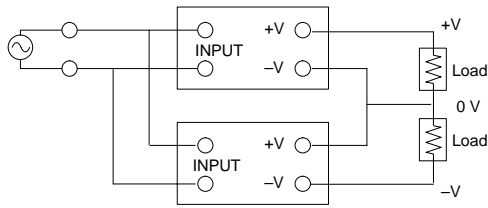

If operation amplifiers as loads are connected in series, connect a diode between the positive and negative output terminals of each Switching Power Supply as shown in the illustration below. Without these diodes, the Power Supplies may not start when power is turned on, possibly damaging internal circuits over a period of time. Use Schottky barrier diodes with a low forward voltage ( $V_F$ ). Other types of diodes will not be effective.

Guidelines for the dielectric strength and current of the diodes are as follows:

Dielectric strength: At least twice the rated output voltage of the Power Supply

Forward current: At least twice the rated output current

No diodes are required for models that allow series operation.

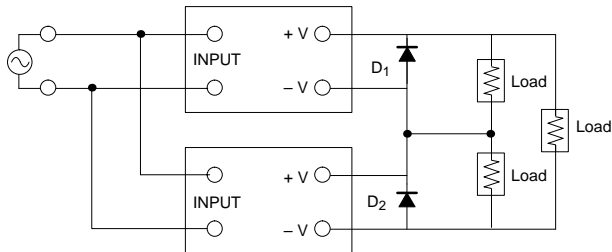

### Series Operation

Only models with power ratings of 50/100/150/300/600 W allow series operation.

As shown in the following diagram, the output voltage from each Switching Power Supply can be added.

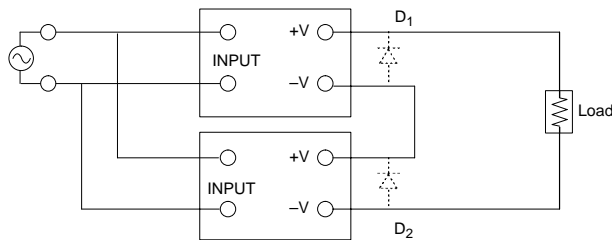

With the S82J-050□□□□ or S82J-10024□□□, if the load is shorted a reverse voltage may result in the Power Supply causing deterioration and damage. It is recommended that diodes are connected as shown in the previous diagram ( $D_1$ ,  $D_2$ ).

### Parallel Operation

Only 300- and 600-W models can be in parallel operation. Do not operate any other models in parallel. The output of the models in parallel operation is a maximum of 80% of the rated output.

Set the parallel operation selector to PARALLEL if the Units are in parallel operation and make sure that the thickness and the length of all wires connected to the load are the same to ensure that the wires will have no voltage drop differences.

### Fan Replacement

The service life of the fan is approximately 50,000 hours (at 25°C). The service life varies, however, depending on the ambient temperature or other surrounding environmental conditions such as dust. As a preventive maintenance measure, replace the fan within two years if it is used at an ambient temperature of 40°C.

Fans are available as replacements.

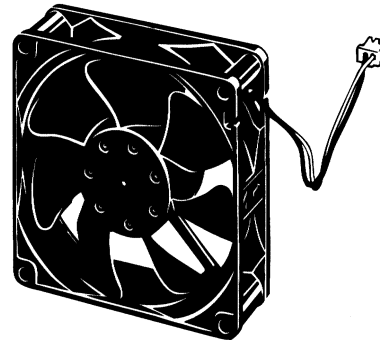

Model: S82Y-JFAN

Fan Set:

Fan (above), four M4 x 35 sems screws, instruction sheet, and packing case

Replace the fan as shown in the following illustration.

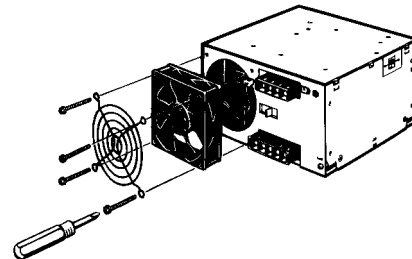

**ALL DIMENSIONS SHOWN ARE IN MILLIMETERS.**

To convert millimeters into inches, multiply by 0.03937. To convert grams into ounces, multiply by 0.03527.

Cat. No. M047-E1-6

In the interest of product improvement, specifications are subject to change without notice.

**OMRON Corporation**

Industrial Automation Company

Measuring and Supervisory Controls Department  
Shiokoji Horikawa, Shimogyo-ku,  
Kyoto, 600-8530 Japan  
Tel: (81)75-344-7108/Fax: (81)75-344-7189

Printed in Japan  
0301-2M (A)