

Cam Positioner

Economical Electronic Cam Switch with High-performance Eight-cam Control

- Easy replacement of mechanical cam switches.
- Easy setting with single-function keys (each key has one function).
- Accepts 330-rpm input for compatibility with a variety of automatic units for operation timing control.
- Equipped with useful functions for switching encoder rotation direction, designating the encoder origin, etc.
- Bright LCD backlight display.
- Up to 16-cam control possible using parallel input adapter and two H8PSs.
- Conforms to EMC standards.
- Approved by UL and CSA.
- Six-language instruction manual provided.



Rotary Encoder

- This encoder works in combination with the H8PS Cam Positioner to detect the operation timing of various automatic machines at high precision.
- The E6CP is a low-cost money-saving encoder.
- The E6F is compatible with high shaft-tolerance applications as well as environments subjected to water and oil.



Ordering Information

■ Cam Positioner

Mounting method	Output configuration	Model
Flush	NPN transistor output	H8PS-8B
	PNP transistor output	H8PS-8BP
Surface/Track	NPN transistor output	H8PS-8BF
	PNP transistor output	H8PS-8BFP

■ Rotary Encoder

Type	Cable length	Model
Economy	2 m	E6CP-AG5C-C
Rigid		E6F-AG5C-C

■ Accessories (Order Separately)

Item	Specification	Model
Protective Cover	---	Y92A-96B
Shaft Coupling for E6CP	Axis dia.: 6 mm	E69-C06B
Shaft Coupling for E6F	Axis dia.: 10 mm	E69-C10B
Extension Cable (see note)	5 m (same for E6CP and E6F)	E69-DF5
Parallel Input Adapter	---	Y92C-30
Mounting Base	For H8PS-8BF□	Y92F-91
DIN Track	Length: 50 cm	PFP-50N
	Length: 100 cm	PFP-100N(2)
Spacer	---	PFP-S
End Plate	---	PFP-M

Note: Please inquire about the availability of non-standard lengths.

Specifications

■ Ratings/Characteristics

Cam Positioner

Mounting method	H8PS-8B(P): Flush mounting H8PS-8PF(P): Surface/Track mounting
Rated supply voltage	24 VDC
Operating voltage range	85% to 110% of rated voltage
Power consumption	Approx. 4 W
Setting unit	1° Increments (cam control precision, however, is within 2°: 256° rotational increments) Up to 2 output signals can be set per cam
Inputs	Encoder input: connections to a special absolute encoder (OMRON E6CP/E6F) Response rotation speed: Run mode: 330 rpm max. Switchable between high speed (60 to 330 rpm) and low speed (60 rpm max.) Test mode: 60 rpm max. Includes malfunction data detection
Outputs	Open-collector transistor output NPN: H8PS-8B(F) PNP: H8PS-8B(F)P Cam outputs: 8 lines (Output No.1 to 8) 30 VDC max., 100 mA max. (residual voltage: 2 V max.) RUN OUT: Turns ON in Run and Test modes, OFF in Program mode in case of error 30 VDC max., 100 mA max. (residual voltage: 2 V max.) TACHOMETER: 60-ppr signal output for rpm meter 30 VDC max., 30 mA max. (residual voltage: 0.5 V max. for NPN models, 2 V max. for PNP models)
Encoder cable extension distance	100 m max.
Output response time	Run mode: 0.5 ms max. under high speed designation 2.5 ms max. under low speed designation Test mode: 5 ms max.
Life expectancy of memory back-up battery	10 years (at 25°C)
Insulation resistance	100 MΩ min. (at 500 VDC) between current-carrying terminal and exposed, non-current-carrying metal part
Dielectric strength	1,000 VAC, 50/60 Hz for 1 min between current-carrying terminal and exposed, non-current-carrying metal part
Impulse withstand voltage	1 kV between power terminals, 1.5 kV between current-carrying terminal and non-current-carrying metal part
Noise immunity	±480 V between power terminals for square-wave noise from noise simulator (pulse width: 100 ns/1 μs, 1 ns at startup)
Static immunity	Destruction: 15 kV Malfunction: 8 kV
Vibration resistance	Destruction: 10 to 55 Hz 0.75-mm single amplitude each in X, Y, and Z directions Malfunction: 10 to 55 Hz 0.5-mm single amplitude each in X, Y, and Z directions

Shock resistance	Destruction: 300 m/s ² (approx. 30 G) Malfunction: 200 m/s ² (approx. 20 G)
Display method	LCD with back light
EMC	(EMI): EN50081-2 Emission Enclosure: EN55011 Group 1 class A (EMS): EN50082-2 Immunity ESD: EN61000-4-2: 4 kV contact discharge 8 kV air discharge Immunity RF-interference: ENV50140: 10 V/m (Amplitude-modulated, 80 MHz to 1 GHz) 10 V/m (Pulse-modulated, 900 MHz) Immunity Conducted Disturbance: ENV50141: 10 V (0.15 to 80 MHz) Immunity Burst: EN61000-4-4: 2 kV power-line 2 kV I/O signal-line
Approved standards	UL508, CSA C22.2 No.14, conforms to EN50081-2 and EN50082-2
Ambient temperature	Operating: -10°C to 55°C (with no icing) Storage: -25°C to 65°C (with no icing)
Ambient humidity	Operating: 35% to 85%
Weight	Approx. 300 g

Rotary Encoder

Item	E6CP-AG5C-C	F6F-AG5C-C
Rated supply voltage	12 VDC -10% to 24 VDC +15%, ripple (p-p) 5% max.	
Current consumption	70 mA max.	
Resolution (per revolution)	256 (8-bit)	
Output code	Grey binary	
Output method	Open collector output	
Output capacity	Applied voltage: 28 VDC max. Sink current: 16 mA max. Residual voltage: 0.4 V max. (sink current at 16 mA)	Applied voltage: 30 VDC max. Sink current: 35 mA max. Residual voltage: 0.4 V max. (sink current at 35 mA)
Logic	Negative logic (H = 0, L = 1)	
Precision	Within ±1°	
Rotation direction	Clockwise (viewing from the shaft) for output code increment	
Rise and fall times of output	1 μs max. (control output voltage: 16 V; load resistance: 1 kΩ; output cord: 2 m max.)	1 μs max. (control output voltage: 5 V; load resistance: 470 Ω; output cord: 2 m max.) 2 μs max. (control output voltage: 5 V; load resistance: 1 kΩ; output cord: 2 m max.)
Startup torque	10 gf-cm max.	100 gf-cm max.
Moment of inertia	10 gf-cm ² max.	15 g-cm ² max.
Shaft-load tolerance	Radial	10 kgf
	Thrust	3 kgf
Max. rpm threshold	1,000 rpm	5,000 rpm
Ambient temperature	Operating: -10°C to 55°C (with no icing) Storage: -25°C to 85°C (with no icing)	Operating: -10°C to 60°C (with no icing) Storage: -25°C to 80°C (with no icing)
Ambient humidity	35% to 85% (with no condensation)	
Enclosure ratings	IEC standard IP50	IEC standard IP52F
Insulation resistance	10 MΩ max. (at 500 VDC) between charged parts and the case	
Dielectric strength	500 VAC, 50/60 Hz for 1 min between charged parts and the case	
Vibration resistance	Malfunction: 10 to 55 Hz, 1.5-mm double amplitude each in X, Y, and Z directions	
Shock resistance	Malfunction: 100 G for 3 times each in X, Y, and Z directions	
Weight	Approx. 200 g (with 2-m cord)	Approx. 500 g (with 2-m cord)

Nomenclature

Display

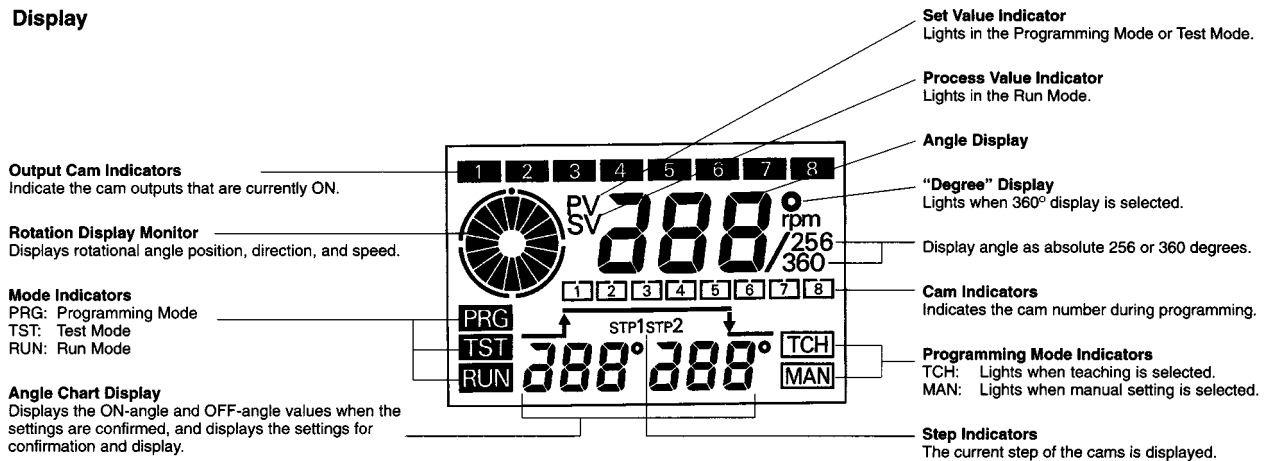

Operations

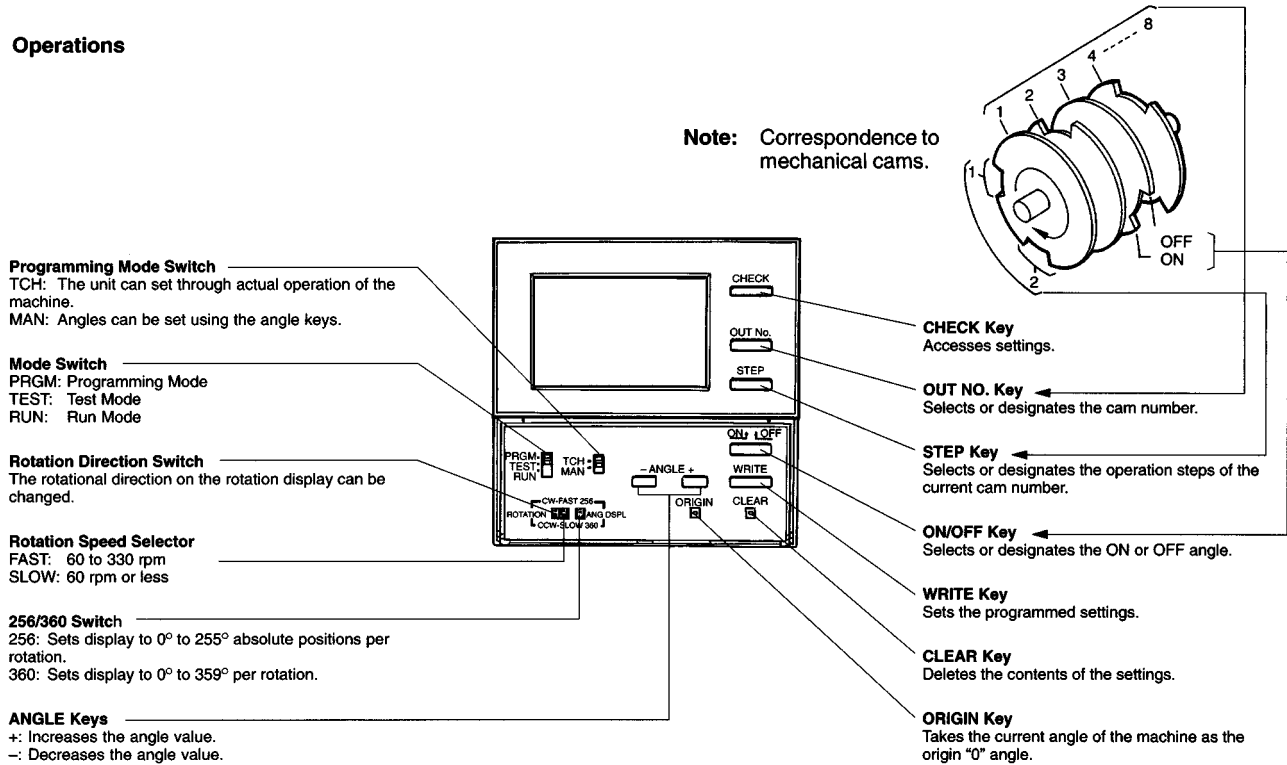

Operation

■ Functions

Classifications	Functions
Encoder rotational direction switch	Encoder data revolutions can be set to clockwise or counterclockwise.
Encoder origin designation	The process display angle can be set to the origin as 0° at the press of a button.
Angle display switch	The unit can convert the display of absolute encoder values 256 divisions/revolution to 360°/revolution.
Rotation display monitor	Graphic display of encoder rotational angle position.
Teaching	The unit can set the ON/OFF angle from actual operation of the machine.
Monitor contents	Process value display (character height: 11 mm), output display, settings display, set cam number display, mode display, revolution display, operation step display, and error message display.

■ Operation

The H8PS Cam Positioner receives angle signal inputs from the Encoder, and outputs the preset ON/OFF angles as control signals (cams number 1 to 8).

Program Example

Control output (cam number)	STEP 1		STEP 2	
	ON angle	OFF angle	ON angle	OFF angle
1	45°	180°	---	---
2	0°	90°	180°	270°
.
.
.
8	135°	225°	315°	45°

Operation Example

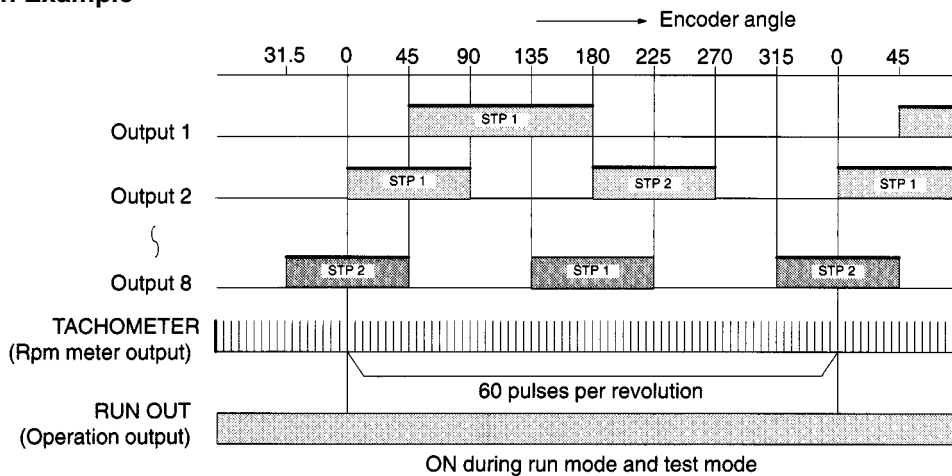

Note: 1. When the setting angles for STEP 1 and STEP 2 of same output are overlapped, the operation is as follows:

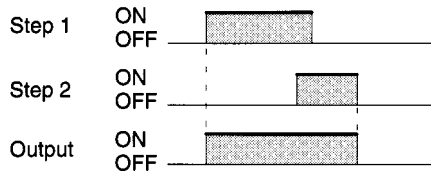

2. The operating output "RUN OUT" does not turn ON during programming. The operation output turns ON with the timing shown in the diagram, but it remains OFF when an error occurs. Thus, you can use the output as a timing signal during operation, including test runs.



■ Initializing

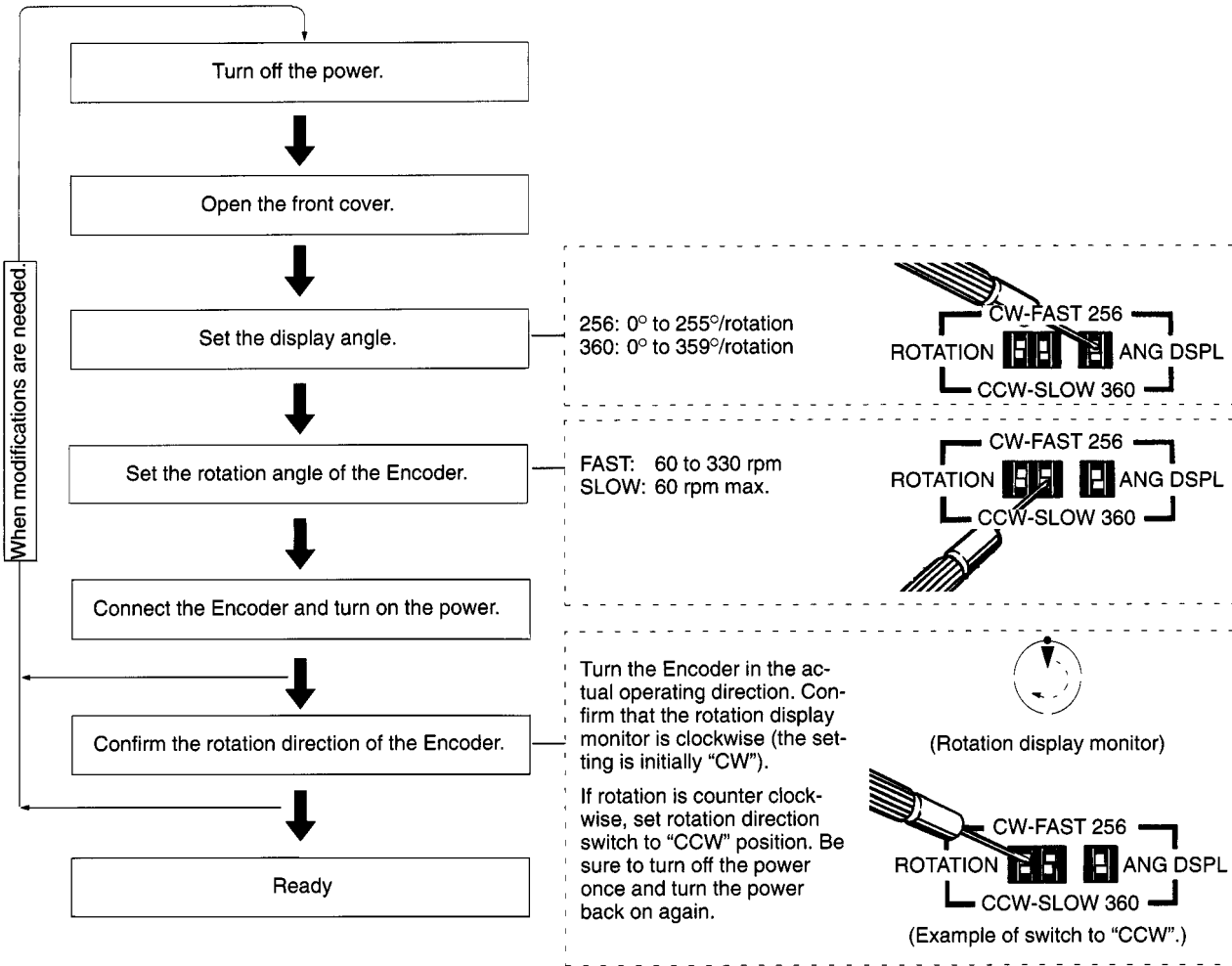

■ Actual Setting Example

1. Setting the Origin

Any mode can be used to set the origin except for the Run Mode.
Ex. Set the process value of 180° to 0°.

- a. Set the mode switch to PRGM.
- b. Set the programming mode switch to TCH.

Mode	Programming Mode
PAGM TEST RUN	TCH MAN

Initial Display

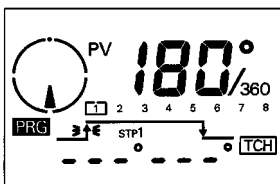

- c. Adjust the machine (Encoder) to the position of the desired origin (180° in the example).
- d. Press the ORIGIN Key.

Go back to the initial display.

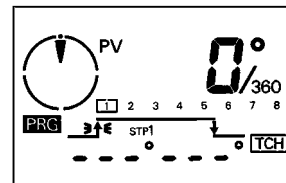

2. Setting of Modifying the ON or OFF Angle

Set or modify with the Angle Keys.

Ex. Set cam number 2 step 2 to turn ON at 30° and turn OFF at 41°.

- a. Set the mode switch to PRGM.
- b. Set the programming mode switch to MAN.

Mode	Programming Mode
PAGM TEST RUN	TCH MAN

Initial Display

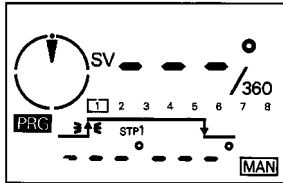

- c. Press the OUT NO. Key and select "2" for cam number 2. Keep pressing the key for automatic increment or decrement.
- d. Press the STEP Key and select "STP2" for step 2.

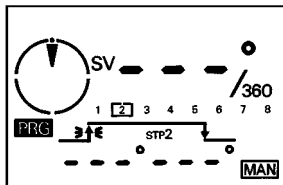

- e. Press the ON/OFF Key to set the ON angle.
- f. Press the + or – Keys to set to "30."
- g. Press the WRITE Key.

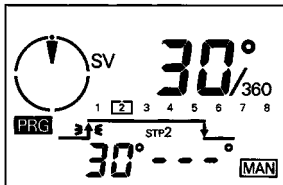

- h. Press the ON/OFF Key to set the OFF angle.
- i. Press the + or – Keys to set to "41."
- j. Press the WRITE Key.

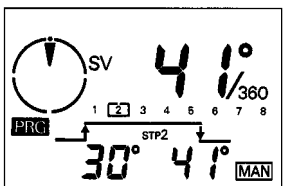

Note: Pressing the + or – Key continually will automatically increment or decrement the value. Pressing the other key during automatic increment or decrement will increase the speed.

3. Setting or Modifying the ON/OFF Angle Set or Modify by Teaching

Ex. Set the ON/OFF angle by teaching step 1 of cam number 3.

- a. Set the mode switch to PRGM.
- b. Set the programming mode switch to TCH.

Mode	Programming Mode
PAGM TEST RUN	TCH MAN

Initial Display

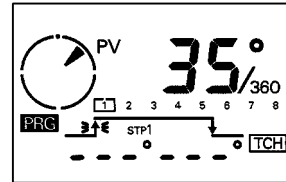

- c. Press the OUT NO. Key and select "3" for cam number 3.
- d. Press the STEP Key and select "STP1" for step 1.

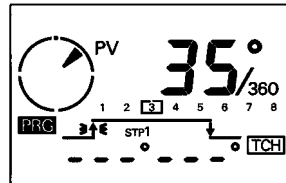

- e. Press the ON/OFF Key to set the ON angle.
- f. Adjust the machine (Encoder) and set it at the output ON position (125° in the example).
- g. Press the WRITE Key.

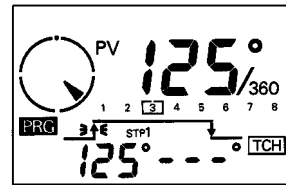

- h. Press the ON/OFF Key to set the OFF angle.
- i. Adjust the machine (Encoder) and set it at the output OFF position (312° in the example).
- j. Press the WRITE Key.

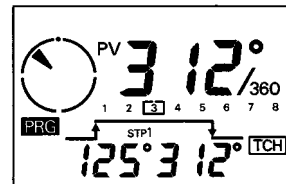

Note: If the machine (Encoder) is operated at a speed greater than permitted, an "E2" error will occur.

Dimensions

Note: 1. All units are in millimeters unless otherwise indicated.
 2. □ denotes square dimensions.

■ Cam Positioner

Flush Mounting Models
 H8PS-8B
 H8PS-8BP

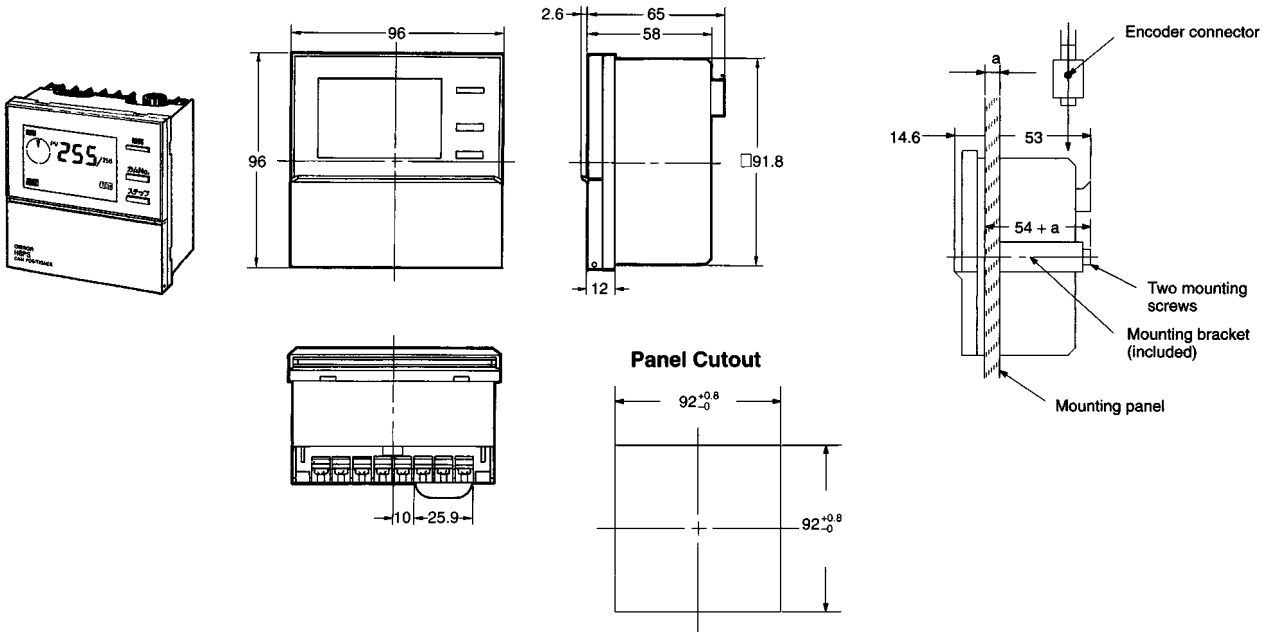

Surface-mounting/Track-mounting Models
 H8PS-8BF
 H8PS-8BFP

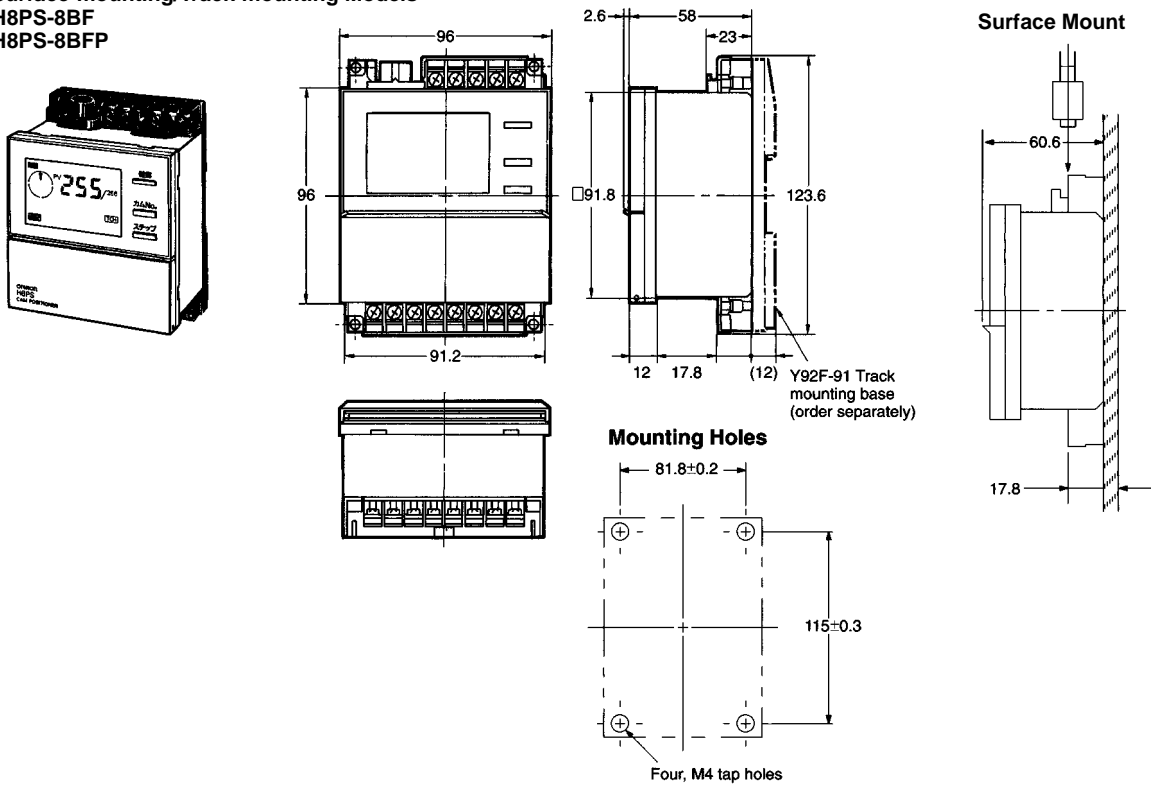

Track Mount
H8PS-8BF/8BFP with Y92F-91

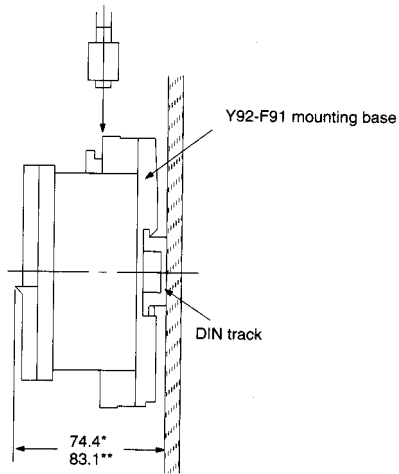

*for PFP-100N or PFP-50N.
**for PFP-100N2.

■ **Accessories (Other Separately)**

Protective Cover
Y92A-96B

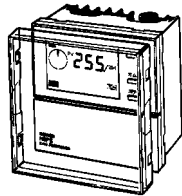

Track Mounting Base
Y92F-91

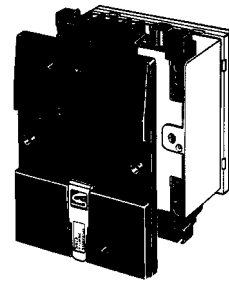

Adapter for Parallel Operation

This Adapter enables two H8PS Cam Positioners to share a signal from an Encoder.

Use the cable marked with triangle mark when connecting only one H8PS Cam Positioner to the adapter.

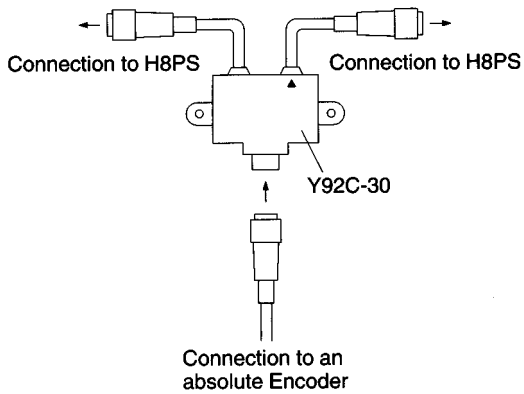

Panel Surface Mounting

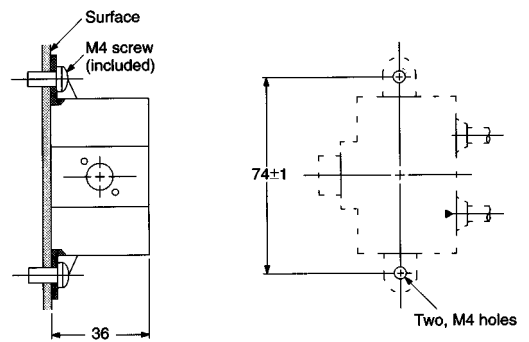

Panel Back Mounting

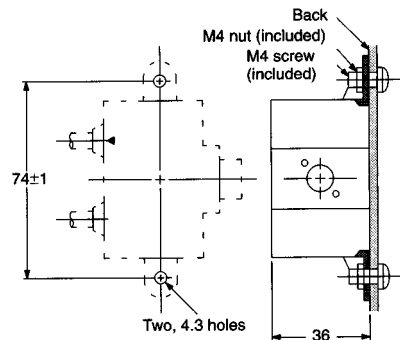

■ Rotary Encoder

E6CP-AG5C-C

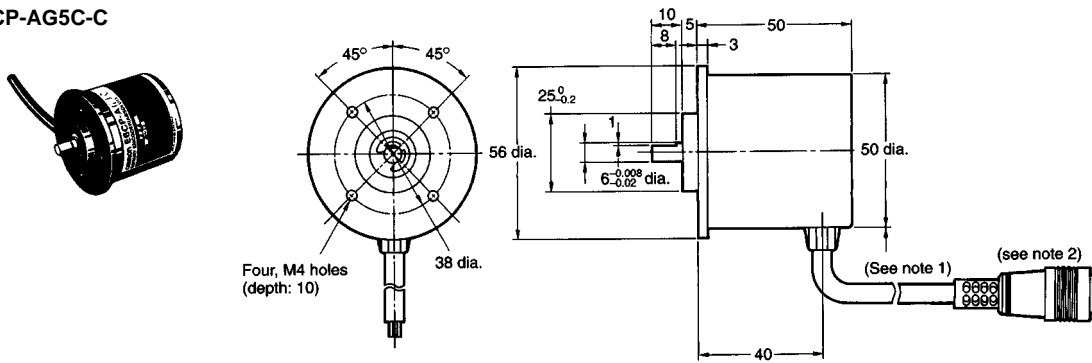

- Note:** 1. Round, vinyl-insulated cord. External dia.: 6 mm; 10/7/0.18-mm dia.; standard: 2 m.
 2. Connector to H8PS (Hirose Electric: RP13A-12PD-13SC)

With Mounting Bracket

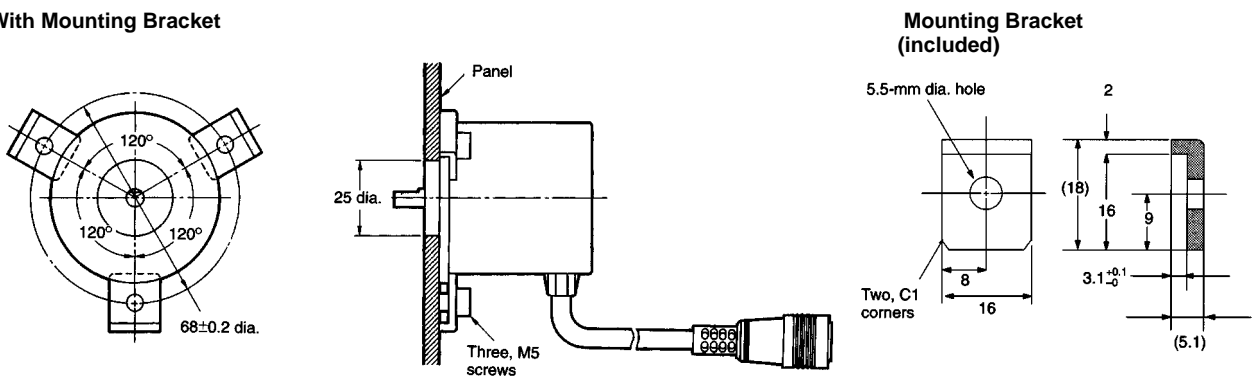

E6F-AG5C-C

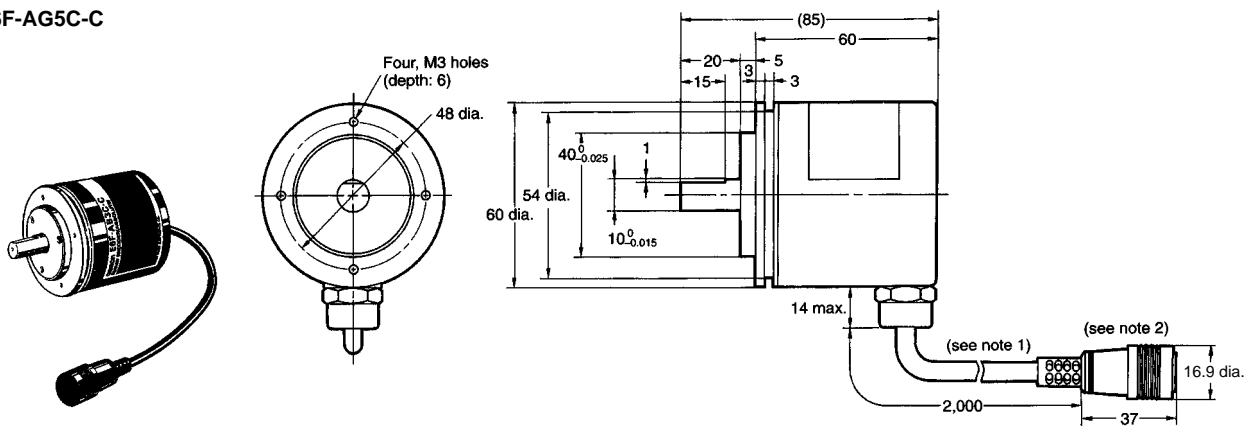

- Note:** 1. Round, vinyl-insulated and shielded cord (oil resistant). External dia.: 6 mm; 12/7/0.18-mm dia.; standard: 2 m.
 2. Connector to H8PS (Hirose Electric: RP13A-12PD-13SC)

With Mounting Bracket

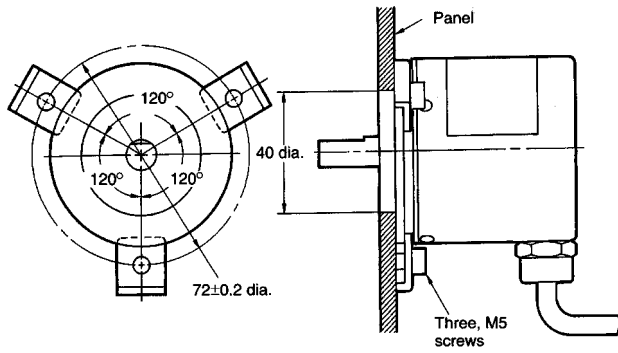

Mounting Bracket (included)

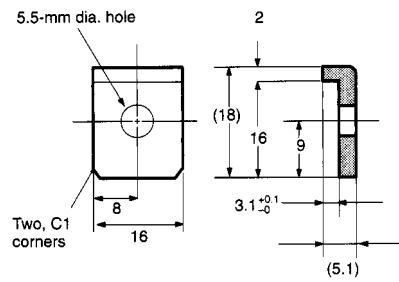

■ Accessories for Rotary Encoder

Shaft Coupling (for E6CP)
E69-C06B

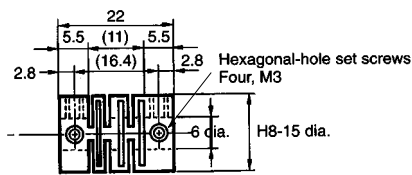

Shaft Coupling (for E6F)
E69-C10B

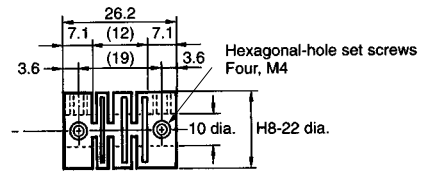

Note: The material is polyacetal resin with glass fibers (GC-25).

Extension Cable
E69-DF5

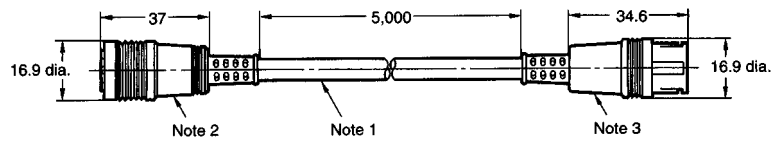
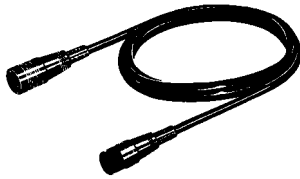

Note: 1. Round, vinyl-insulated and shielded cord (oil resistant).
External dia.: 6 mm; 12/7/0.18-mm dia.; 5 m.
2. Connector for H8PS (E6F-AB3C-C, E6F-AG5C-C)

Installation

Terminal Arrangement

H8PS-8B

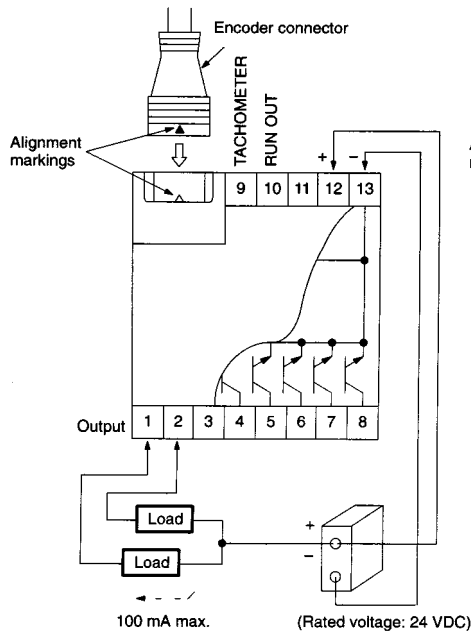

H8PS-8BF

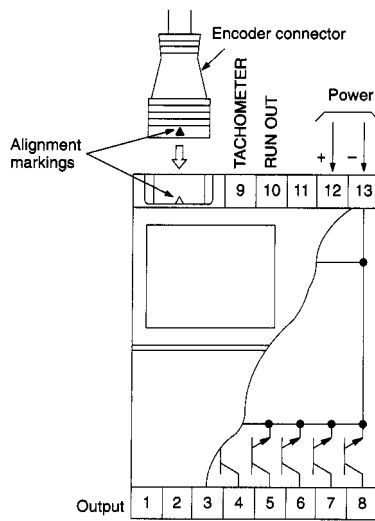

Output Circuit

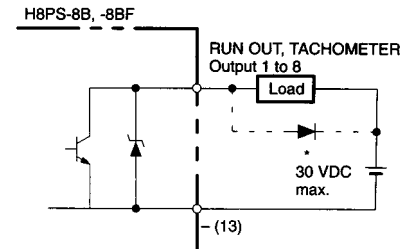

*When using an inductive load, connect a reverse surge-absorbing diode.

H8PS-8BP

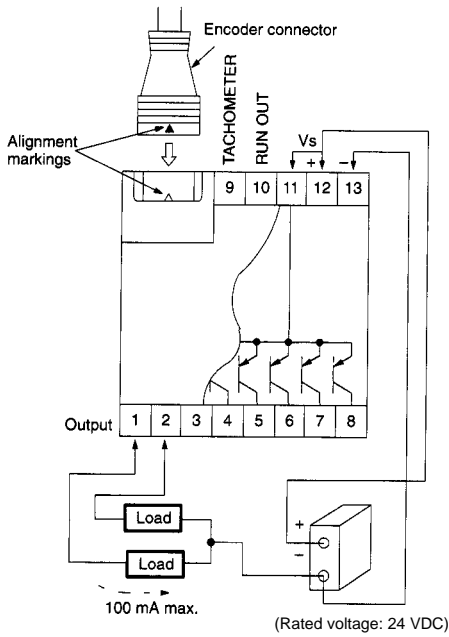

H8PS-8BFP

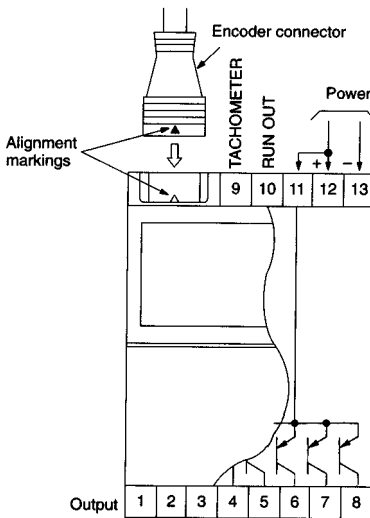

Output Circuit

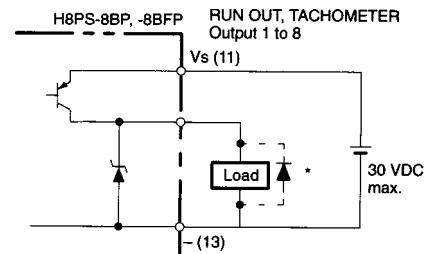

* When using an inductive load, connect a reverse surge-absorbing diode.

Item	H8PS-8B/-8BF		H8PS-8BP/-8BFP	
	RUN OUT Output 1 to 8	TACHOMETER	RUN OUT Output 1 to 8	TACHOMETER
Output method	NPN open collector		PNP open collector	
Dielectric strength	30 V		30 V	
Rated current	100 mA	30 mA	100 mA	30 mA
Residual voltage	2 V max.	0.5 V max	2 V max.	
Leak current	100 μ A max.	5 μ A max.	100 μ A max.	

Note: Internal circuit damage can result from a short circuit in the load.

Multiple outputs (OUTPUT 1 to 8) can be connected to operate a load as shown below.

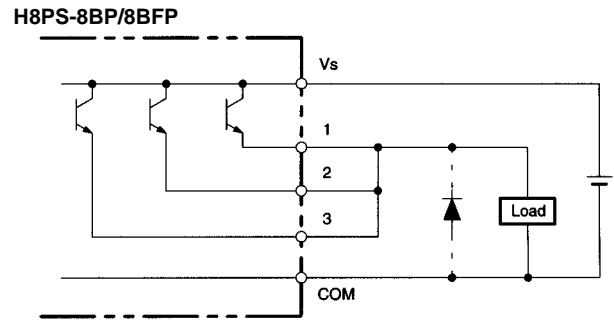
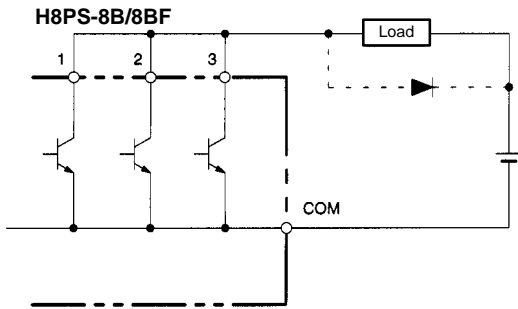

Timing Chart

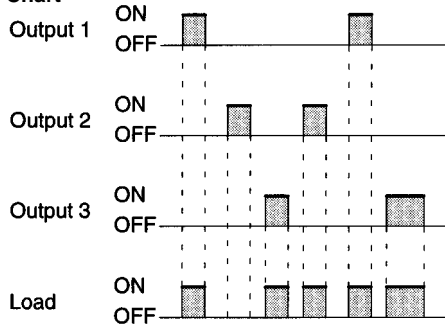

Connection Examples

TACHOMETER Connection

Since the rotational output consists of 60 pulses per revolution, select an appropriate rpm meter.

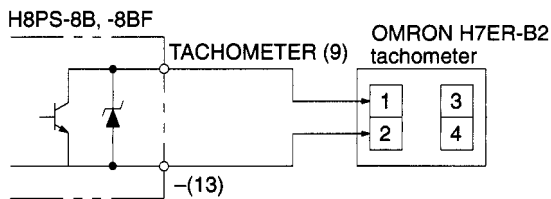

RUN OUT Connection

The output is ON during run and test modes and can be used as a status signal by connecting to the Input Unit of a Programmable Controller (SYSMAC) or similar device.

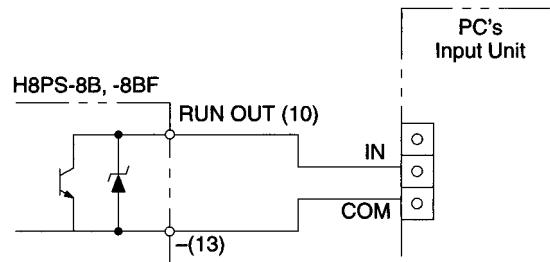

Precautions

Cam Positioner

Error Displays and Cancelling

When an error occurs, perform the following cancellation operation. (When the following errors occur, all outputs turn OFF except for the TACHOMETER output.)

Display	Description	Cancellation method
E0	Set origin data error	Reset the origin in the Programming Mode and return to the previous mode.
E1	Memory error, when settings have been modified	Switch to the Programming Mode and confirm all settings. After correcting the settings, return to the previous mode.
E2	Encoder input data error 1. The Encoder is malfunctioning or a connector is disconnected. 2. The Encoder rotation speed exceeds the response limit. 3. The Encoder output data became scrambled because of noise. 4. A line to the Encoder is cut.	Switch to the Programming Mode and check the following items. Return to the previous mode after corrections. 1. Encoder abnormality 2. Faulty Encoder connector contacts 3. Encoder rotation speed and response speed settings 4. Noise and surge protection

After turning on the power, it takes approximately two seconds until normal operation,

When the ON angle and OFF angle are the same value, no output will occur.

Handling

Turn the operation power on or off instantaneously via a contact such as a switch or relay.

Avoid operation in the following environments:

1. An ambient temperature below -10°C or above 55°C.
2. Very dusty locations.
3. Very humid locations.
4. Locations where corrosive gasses are generated.
5. Locations with heavy vibrations or shock.
6. Locations prone to water or oil.
7. Locations with direct sunlight.

For operation in environments with excessive electrical noise generation, separate the Encoder cords and the main unit of the H8PS from high-power cables that have noise or noise-generating sources.

The external finish of the main unit is prone to organic solvents (thinner, benzene, etc.), strong alkali (ammonia, sodium hydroxide), and strong acid. Please avoid contact with these chemicals.

Store the devices between -25°C and 65°C. For storage below -10°C, power the unit up after letting it stand at room temperature for three hours.

To perform dielectric testing, impulse-voltage testing, and insulation-resistance measuring between the electrical circuitry and the uncharged metal parts when the unit is mounted in a control panel, first disconnect the wiring of the unit from the circuitry. (This prevents degradation of damage of internal circuitry in the event that part of the control-panel equipment has faulty voltage resistance or faulty insulation. The test voltage might go to the power-supply terminals of the main unit.)

The Encoder consists of precision parts. Exercise care in handling, and make sure no excessive shock or pressure is applied to the Encoder. Especially make sure that the Encoder's rotating shaft is not subjected to excessive force.

The connections for the main unit connectors should have no undue stress applied. Wire cables accordingly.

Angle Data Table

The H8PS uses an absolute Encoder with 256 divisions per revolution. To assist with programming, displays and settings may be done by conversion to 360 degrees by a switch on the front panel. The following table shows the conversions.

How to Use the Table

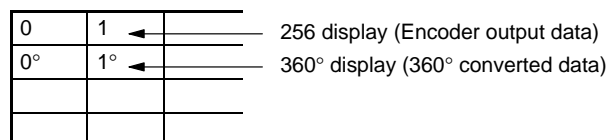

0	1	2	3	4	5	6	7	8	9	10	11	12	13	14	15
0°	1°	3°	4°	6°	7°	8°	10°	11°	13°	14°	15°	17°	18°	20°	21°
16	17	18	19	20	21	22	23	24	25	26	27	28	29	30	31
23°	24°	25°	27°	28°	30°	31°	32°	34°	35°	37°	38°	39°	41°	42°	44°
32	33	34	35	36	37	38	39	40	41	42	43	44	45	46	47
45°	46°	48°	49°	51°	52°	53°	55°	56°	58°	59°	60°	62°	63°	65°	66°
.
.
.
208	209	210	211	212	213	214	215	216	217	218	219	220	221	222	223
293°	294°	295°	297°	298°	300°	301°	302°	304°	305°	307°	308°	309°	311°	312°	314°
224	225	226	227	228	229	230	231	232	233	234	235	236	237	238	239
315°	316°	318°	319°	321°	322°	323°	325°	326°	328°	329°	330°	332°	333°	335°	336°
240	241	242	243	244	245	246	247	248	249	250	251	252	253	254	255
338°	339°	340°	342°	343°	345°	346°	347°	349°	350°	352°	353°	354°	356°	357°	359°

WARNING

1. The H8PS has a built-in lithium battery. Be sure to dispose of the old H8PS properly, as lithium batteries are likely to explode if incinerated.
2. Electrical shock hazard
Never touch the input terminals of any H8PS Cam Positioner when power is being applied to the Cam Positioner.

■ Rotary Encoder

Make sure that the E6CP Encoder is not subjected to oil or water. If oil or water enters the interior, malfunctions may occur. For use in environments subject to water drops or oil, use the E6F.

Rotary Encoders consist of precision parts. Their operation may be damaged if the Encoder is dropped. Be very careful with handling.

When joining to a chain, timing belt, or gears, interpose a coupling and bearings before the Encoder.

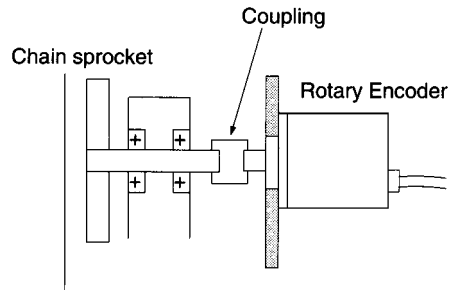

Large mounting deviations (eccentric centers or angles) may cause an excessive load on the Encoder's shaft, resulting in damage or drastically reduced life expectancy. Take care not to place excessive loads on the shaft.

Keep the tightening torque around 5 kg • cm when fastening the rotary Encoder.

Do not pull the wiring at a force greater than 3 kg when the main unit is fastened and wired.

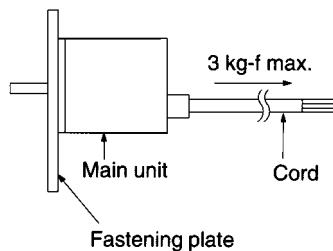

If you insert a coupling on the shaft, do not hammer on the coupling or otherwise subject it to shock.

Mounting Procedure

1. Place a coupling on the shaft.
Do not screw the coupling and shaft tight.
2. Fasten the Encoder.
Do not insert the shaft to the coupling more than the length shown below.

Shaft coupling	Length of insertion
E69-C06B	5.5 mm
E69-C10B	7.1 mm

3. Fasten the coupling.

Shaft coupling	Tightening torque
E69-C06B	2.5 kgf • cm
E69-C10B	4.5 kgf • cm

4. Connect power supply and input/output lines.
Make sure you turn off the power supply when wiring.
5. Turn on the power and check outputs.

ALL DIMENSIONS SHOWN ARE IN MILLIMETERS.

To convert millimeters into inches, multiply by 0.03937. To convert grams into ounces, multiply by 0.03527.

Cat. No. M041-E1-3C **In the interest of product improvement, specifications are subject to change without notice.**

OMRON Corporation

Industrial Automation Company

Measuring and Supervisory Controls Division
28th Fl., Crystal Tower Bldg.,
1-2-27, Shiromi, Chuo-ku,
Osaka 540-6028 Japan
Phone: (81)6-6949-6035 Fax: (81)6-6949-6069

Printed in Japan
0499-0.5C (0499)